

DETC2001/DTM-21709

FUNCTIONAL MODELING EXPERIMENTAL STUDIES

Mark A. Kurfman & Robert B. Stone[†]
Department of Basic Engineering
University of Missouri-Rolla
Rolla, MO 65401
rstone@umr.edu

Jagan R. Rajan & Kristin L. Wood
Department of Mechanical Engineering
The University of Texas at Austin
Austin, TX 78712
wood@mail.utexas.edu

ABSTRACT

As more design methodologies are researched and developed, the question arises as to whether these new methodologies are actually advancing the field of engineering design or instead cluttering the field with more theories. There is a critical need to test new methodologies for their contribution to the field of design engineering. This paper presents the results of research attempts to substantiate repeatability claims of the functional model derivation method. Three experiments are constructed and carried out with a participant pool that possesses a range of engineering design skill levels. The experiments test the utility of the functional model derivation method to produce repeatable functional models for a given product among different designers. Results indicate the method is largely successful and identify its key strengths as well as opportunities for improvement.

1 INTRODUCTION

Functional modeling is an integral part of the design process. The widespread usage of functional modeling in many contrasting and complementary forms motivates the design community to search for a unified, systematic and formal theory of functional modeling. Many of the current theories lack the scientific data required to substantiate their usefulness. This lack of validation often hinders their acceptance in both industry and academia. If functional modeling can be experimentally proven as a beneficial and repeatable design tool, it would open a world of possible applications.

One of the most promising area is computer aided design (CAD). Just as computer aided design has revolutionized the field of engineering over the past twenty years, functional modeling offers an analogous leap. Over the years, CAD has benefited the field of engineering by increased productivity, reducing a product's time to market, and improving manufacturability. Unfortunately, current CAD applications are only able to capture a product's geometrical feature, but not a

product's function or behavior. If a tool is developed that can perform these operations, an engineer would no longer search a database for merely geometric representation, but instead look for products similar in function. In other words, by having a product's function captured, an engineer could design by analogy [1], therefore greatly reducing design time and increasing creativity.

Another area that a common functional modeling language could be of great benefit is in the area of conceptual product architecture development [2,3]. Modular products offer tremendous benefits in terms of interchangeability, using common parts and reducing manufacturing costs [4]. Unfortunately, in many instances the benefits of a modular architecture may not be realized until after an initial prototype is produced. By using functional modeling, it is possible to develop product architectures earlier in the product development process. Stone *et al.* [2, 3] use heuristics in order to develop useful architectures. All of this, however, is dependent on a common and repeatable functional model. Therefore, these benefits of functional modeling drive researchers to develop a tool that accomplishes these goals.

In this article, we look at the repeatability of the functional basis derivation methodology. In Section 2 we review current and past function-based design methodologies. Section 3 contains details discussing the procedure of a functional modeling repeatability experiment. The results and data analysis are discussed in Section 4 before conclusions are made in Section 5.

2 BACKGROUND

Functional modeling in engineering design research theory is a well-researched and active field of engineering study. There are numerous functional modeling methodologies, all of which follow a similar procedure. They begin with an overall product function and then break that function down into sub-functions. The most well-known functional modeling methodology

[†] Corresponding author, 102A Basic Engineering Building, University of Missouri-Rolla, Rolla, MO 65409-0210; Phone: 573-341-4086; E-mail: rstone@umr.edu.

following this approach is that of Pahl and Beitz [5]. They model the overall function and decompose it into sub-functions operating on the flows of energy, material, and signals. Their functional approach was a great advance for engineering design, but their methodology did not provide an all-encompassing list of sub-functions to describe all possible engineering systems or produce repeatable function structures. Since then, many researchers have sought to fill in the missing portions of Pahl and Beitz's work [6, 7, 8, 9, 10, 11, 12]. The problem with many of these function based design methodologies is their inability to produce repeatable functional models of a particular product. Two engineers can be given the same product, customer needs, and process choices, but the likelihood of them producing similar function structures is low. Some designers have suggested that this is the essential flaw with functional modeling and therefore disregard its significance. Others have taken a different approach and tried to resolve this problem by developing a common language to create functional models.

Developing a common language for functional modeling can trace its beginnings back to the study of value analysis [13, 14, 15]. In this work, they define all of their functions using a verb and a noun, but they go one step further than the previously mentioned design methodologies by developing suggested verb-noun lists. Their lists, however, are not complete and cannot begin to describe all of the possibilities that one might encounter in engineering. Collins *et al.* [16] used over 500 individual failed parts from helicopters to propose a list of elemental mechanical functions to classify their failure. Their investigation resulted in a list of 105 elemental mechanical functions that can be used to classify helicopter failure data. While very useful, its scope is limited to helicopter applications.

Modarres [17] uses conservation principles to develop a common vocabulary for functional modeling. Using his methodology, an engineering system can be described using input and output flows of mass, energy, and signals, which he terms *main commodities*. His methods are very similar to Pahl and Beitz's [5] function based method, but Modarres goes on to further describe the system by defining *support commodities*. These *support commodities* enter the systems boundaries and make the energy conversion possible. His functional classification system has seven main categories and these are further decomposed into 24 major forms. He also classifies six *functional primitives* that are used in the processing of commodities. Modarres does not specify a format to create functions such as the *verb-object* format described in Pahl and Beitz [5] which leaves room for variability between different users. His classification system is more appropriate for mechanical systems and is lacking in appropriate *functional primitives* for the processing of signals.

Another example of a function classification system is the TROPOS functional modeling language [18, 19] developed for the modeling of industrial maintenance problems. Using two classes of words, *role class* and *form class*, the TROPOS vocabulary identifies different industrial plant activities. The application of TROPOS is limited to industrial plant applications.

Szykman *et al.* [20] has developed a functional vocabulary that is used to represent a product's function and its link to product form. This form dependence hinders its use during the conceptual design phase, but is a great advance towards a repeatable functional model. Stone and Wood [21] develop a function and flow vocabulary they call the functional basis. This work sought to identify functions and flows describing the entire mechanical design space and selected the name functional basis to imply the mathematical characteristics of a basis - spanning the space and exhibiting linear independence. Recently, these two works have been integrated to form the reconciled functional basis [22]. The reconciled flow and function sets are shown in Tables 1 and 2.

Table 1. Flow classes and their basic categorizations.

Class	Basic	Class	Basic
Material	Human	Energy (cont.)	Biological
	Gas		Chemical
	Liquid		Electrical
	Solid		Electromagnetic
	Plasma		Hydraulic
	Mixture		Magnetic
Signal	Status		Mechanical
	Control		Pneumatic
Energy	Human		Radioactive
	Acoustic		Thermal

Table 2. Function classes and their basic categorizations.

Class	Basic	Class	Basic
Branch	Separate	Convert	Convert
	Distribute	Provision	Store
Channel	Import		Supply
	Export	Sense	
	Transfer	Indicate	
	Guide	Process	
Connect	Couple	Support	Stabilize
	Mix		Secure
Control Magnitude	Actuate		Position
	Regulate		
	Change		
	Stop		

One common thread of these function-based design methodologies is the lack of testing and validation. As suggested by Antonsson [23] there is a great need for hypothesis generation and testing related to engineering design theories. He goes on to detail a possible procedure to follow. Antonsson's experimental procedure is adopted for the work reported here. This paper is a significant extension of previous

functional modeling research and offers statistical measures of the repeatability of our functional modeling methodology [2, 3, 21, 24, 25, 26].

3 FUNCTIONAL MODELING REPEATABILITY EXPERIMENT

To begin, we define the process of deriving a functional model as consisting of five steps. These steps, shown schematically in Fig. 1, are: 1) identify flows that address customer needs, 2) generate a black box model, 3) create function chains for each input flow, 4) aggregate function chains into a functional model, and 5) verify the functional model with customer needs [26].

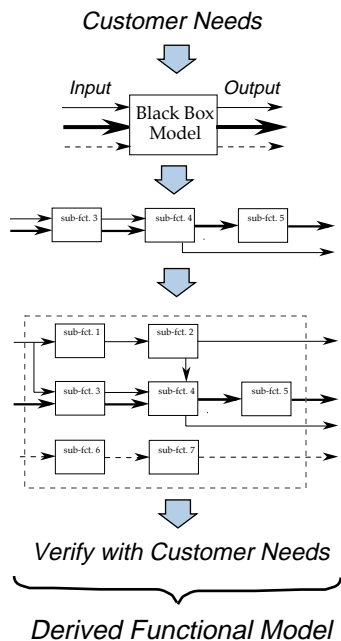

Figure 1. Steps of the functional derivation method.

Our hypothesis is that using the functional model derivation method, as described above, will produce repeatable functional models among different designers, given the same customer needs and process choices. In order to test this hypothesis we develop a functional modeling repeatability experiment. This experiment builds on previous efforts [26] at measuring the functional model derivation method’s repeatability. Here we propose and follow a more rigorous experimental procedure. Our experiment is designed to identify if repeatability gains may be made when designers use the functional basis vs. no formal vocabulary. Additionally, we explore any difference that exist between redesign and original design cases. In constructing the repeatability experiment, we develop the following experimental plan,

1. Prepare a functional modeling methodology that can be used to create functional models.
2. Have designers learn the functional modeling methodology.

3. Have designers apply the methodology on original and existing product designs.
4. Compare the functional models, and either validate or disprove our hypothesis.

Implementation of this experimental plan consists of three different experiments. Test subjects consist of academic and industrial designers and mechanical engineering design students at The University of Texas at Austin and the University of Missouri-Rolla, with a final sample size of twenty-one persons. The repeatability experiment is administered as three separate components. The details of each experimental component are given in the following sections.

3.1 Experiment 1

Experiment 1 is designed to provide a baseline of each subject’s functional modeling capability. The first experiment consists of giving the test subjects a Nerf® Ball Blaster and a set of customer needs. A picture of the Nerf® Ball Blaster is shown in Fig. 2, and a list of the customer needs is given in Table 3. The test subject is asked to create a functional model for the Nerf® Ball Blaster using any functional modeling method that they prefer. Additionally, a brief questionnaire is given to identify each subject’s experience with functional modeling and design work.



Figure 2. Nerf® Ball Blaster.

Table 3. Nerf® Ball Blaster Customer Needs List.

Customer Need	Importance
Shoot balls a long distance	5
Easy to hold	4
Reliably hold a large number of balls	5
Shoots accurately	5
Human powered with minimum exertion	5
Lightweight	3
Colorful	3

3.2 Experiment 2

Experiment 2 introduces the functional model derivation method to the subjects and captures any improvement that occurs in their functional model. The second experiment asks the subject to once again develop a functional model for the Nerf® Ball Blaster using the product and the customer needs

list. In this experiment, however, they are asked to read a “How to Manual” detailing the functional model methodology. This manual contains excerpts from Stone and Wood [21] and two additional examples on how to create a functional model using the functional basis.

3.3 Experiment 3

In order to test the utility of the functional model derivation method for original design, experiment 3 asks for a functional model of an original design problem. The subject is given two pieces of information. The first is the following design problem, “Design a power supply for radios in which human mechanical energy is stored and delivered as electrical energy.” Since no form is specified, we give the initial process choices of human energy to mechanical energy to electrical energy. This is necessary to compare the subjects’ functional model. The second piece of information was a detailed customer needs list, which can be seen in Table 4.

Table 4. Human Powered Power Supply Customer Needs List.

Customer Need	Importance
Easy to input energy	5
Quiet	4
Long lasting energy supply	5
Easy to connect/detach to radio	4
Supply 12V DC	5
Transportable and small package	5
Impact resistant	2
Doesn’t slide on slick surfaces	3
Lightweight	4
Cost	4
Stylish	3

4 RESULTS

In this section, we analyze the results from the previously discussed functional modeling experiments. For participants in this experiment, test subjects from both academia and industry were recruited. For the results presented in this paper, only participants that completed all three experiments are included, resulting in a final sample size of 21. Before the experiment was given, each test subject was asked to complete a questionnaire. This questionnaire is used to determine the skill level of each test subject and is summarized in Table 5. From this questionnaire we determined that the average functional modeling skill level for the participants in this experiment is very low. For 70 percent of the participants, this experiment is their first introduction to functional modeling. Most of the test subjects have designed a product at some point in their career, but their overall knowledge of a systematic design process is very low. Even with the low functional modeling skill level of the test subjects, the results are very encouraging.

Table 5. Demographics of Test Subjects.

	Number of Test Subjects
Gender	
Male	18
Female	3
Education Level	
M.S.	20
Ph.D.	1
Number of Functional Models Created	
0-5	16
6-10	3
11-50	1
>50	1
Average Number of Products Designed	3 Products

4.1 Repeatability Gains in Terms of Vocabulary

Analysis of the data shows that there is a great reduction in the size of the sub-function space used to describe a product’s functionality when the functional model derivation method is used. These results are shown in Table 6.

Table 6. Sub-function Space.

	Total Number of Sub-Functions Used	Average Number of Sub-Functions per FM
Experiment 1	152	16
Experiment 2	73	19

In the first experiment, the test subjects use 152 different sub-functions to describe the Nerf® Ball Blaster. When the functional model derivation method is followed in experiment 2, only 73 different sub-functions are used to describe the Nerf® Ball Blaster. This is a reduction in the size of the sub-function space by 52 percent. This reduction in sub-function space size can be attributed to the limitation the functional basis places on individual expression of product function. While the knee-jerk reaction of many designers is to avoid limitations on expression, in this case the limited vocabulary of the functional basis improves the clarity of the functional model for communication purposes.

Another interesting point is that as the size of the sub-functions space decreases from experiment 1 to 2, the average number of sub-functions present in a functional model increases from 16 to 19. This is a result of specifying that all subjects model the product at a specific level of detail, forcing most subjects to use multiple sub-functions to express former high-level functions.

The sub-function space for experiment 2 and the sub-function frequency can be found in Table 7 on the following page. This table also displays the control functional model sub-functions (shaded in gray), which is our version of the correct functional model for the Nerf® Ball Blaster. Approximately 11 sub-functions of the controls 28 distinct sub-functions were identified by at least 50% of the students.

Table 7. Sub-Function Space For Nerf® Ball Blaster.

Experiment #2		
Sub-Function	Control FM	Frequency
actuate me		0.10
actuate pe		0.05
actuate solid		0.19
acutate pe		0.05
allow dof to solid		0.05
change gas		0.29
change he		0.05
change me		0.05
change pe		0.05
convert em		0.05
convert he to me	1	0.52
convert he to pe		0.33
convert me to ae		0.05
convert me to pe	1	0.24
convert me to te		0.05
convert pe to ae		0.05
convert pe to he		0.05
convert pe to me	1	0.19
couple solid		0.10
display signal	1	0.14
distribute em	1	0.57
distribute me	1	0.43
distribute pe		0.10
export em	1	0.14
export gas	1	0.29
export he		0.14
export human		0.19
export me		0.19
export pe		0.14
export signal		0.05
export solid	1	0.76
guide em		0.05
guide gas	1	0.38
guide me		0.05
guide pe		0.05
guide solid	1	0.81
guide signal		0.05

Experiment #2		
Sub-Function	Control FM	Frequency
import em	1	0.57
import gas	1	0.67
import he	1	0.81
import human	1	0.95
import me		0.33
import signal		0.05
import solid	1	0.95
indicate solid		0.10
indicate status	1	0.14
measure solid		0.05
position solid		0.05
position signal		0.05
regulate solid	1	0.05
secure gas		0.05
secure me		0.10
secure solid	1	0.38
sense signal		0.14
stabilize me	1	0.14
stabilize solid		0.29
stop gas	1	0.05
stop me		0.05
stop solid		0.14
store gas	1	0.57
store he		0.10
store me	1	0.33
store pe		0.05
store solid	1	0.62
supply gas	1	0.00
supply me	1	0.10
supply solid		0.10
transmit em		0.10
transmit he		0.29
transmit me	1	0.33
transmit pe	1	0.19
transport gas		0.33
transport solid		0.19

As shown in Figs. 3 and 4, there is a remarkable improvement in the clarity and level of detail of the functional model when the functional basis is applied. The two figures below show the progression of one test subject's functional model before and after applying the functional basis.

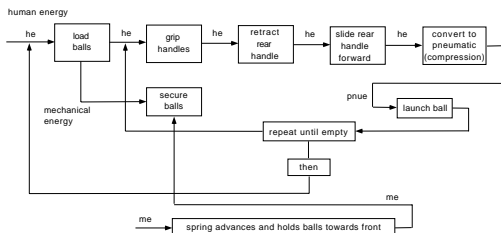

Figure 3. Functional Model of the Nerf® Ball Blaster before applying the functional basis.

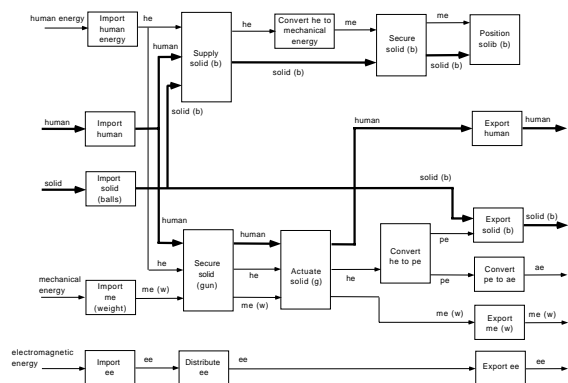

Figure 4. Functional Model of the Nerf® Ball Blaster after applying the functional basis.

Table 8. Sub-Function Space For Power Supply.

Experiment #3		
Sub-Function	Control FM	Frequency
actuate ee		0.10
actuate me	1	0.10
actuate signal		0.05
actuate solid		0.24
allow dof		0.19
change ae		0.10
change ee	1	0.05
change he		0.10
change me	1	0.14
change shape		0.05
change solid		0.05
convert A.E.E. to		0.05
Convert C.E. to D.E.E.		0.05
convert ce to ee		0.05
convert ee to ae		0.05
convert ee to ce		0.05
convert em		0.05
convert he to ee		0.14
convert he to me	1	0.48
convert me to ae		0.05
convert me to ee	1	0.62
convert me to me		0.05
convert pe		0.05
convert pe to ee		0.05
convert R.E. to A.E.E.		0.05
convert signal		0.05
couple solid	1	0.52
display position		0.10
distirbute ae	1	0.10
distribute em		0.29
distribute me	1	0.48
export ee		0.33
export em		0.05
export human	1	0.10
export me		0.05
export solid	1	0.24
extract solid		0.10
guide ee		0.05
guide em		0.05
guide he		0.05
guide me		0.05

Experiment #3		
Sub-Function	Control FM	Frequency
guide solid		0.38
import ee		0.05
import em		0.24
import he	1	0.67
import human	1	0.86
import me		0.33
import Signal		0.10
import solid	1	0.62
indicate Status	1	0.24
measure ee		0.14
position solid		0.29
regulate ee		0.33
regulate me		0.10
regulate signal		0.05
regulate solid		0.05
secure solid	1	0.81
sense ee		0.05
sense load		0.05
sense signal		0.14
separate solid	1	0.14
stabilize me	1	0.29
stabilize solid		0.05
stop ae		0.05
stop ee		0.10
stop me		0.05
store ae		0.05
store ce		0.05
store D.E.E. as C.E.		0.05
store ee		0.71
store he		0.05
store me	1	0.38
store solid		0.05
supply ee		0.43
supply me	1	0.00
transfer he		0.24
transmit ee	1	0.38
transmit em		0.10
transmit me	1	0.29
transmit pe		0.05
transmit signal		0.05
transport solid		0.05

4.2 Original Design Using the Functional Basis

Original design can often be one of the most difficult areas to apply functional modeling. In experiment 3, the results show that our participant pool used 82 distinct sub-functions to describe the human power supply. The sub-function space can be seen in Table 8. From the sub-function space we see that at least 48% of the test subjects identify 8 sub-functions from the 22 distinct sub-functions of the control (control sub-functions shaded in gray).

4.3 Finding the Important Functions

In addition to documenting the frequency with which our experimental subjects use the sub-functions of the control

functional model, we also investigate the ability of designers to identify the most important sub-functions in terms of customer needs. For any product, there is a set of sub-functions that directly meet the high level customer needs. Other sub-functions that are necessary to completely describe the product’s functionality, but do not directly address any customer needs, are called *carrier* functions. Carrier functions are still important, but the overall function of the product is still discernable without their inclusion. Thus, an additional hypothesis is that the functional derivation method leads to functional models among different designers that capture the most important sub-functions in terms of customer needs.

4.3.1 Analysis Methodology

To compare the experimental subjects' functional models generated in experiments 2 and 3 with the respective control functional models, we borrow from the theory used to develop quantitative functional models [2, 3, 27]. Each functional model is converted into a product vector by correlating the weighted customer needs to flows and then following the flows through the sub-functions, as outlined in Fig. 5. The sub-functions are assigned the values of the customer need weighting to form the product vector. For carrier functions, a value of one is assigned in order to document the function's presence in the product. The product vectors are arranged into a $m \times n$ product-function matrix, Φ [2, 3, 28]. Each element ϕ_{ij} is the cumulative customer need rating for the i th function of the j th product. We normalize this matrix to take into account differences in the number of customer needs and functions for each subject's functional model, to remove biases for any one product.

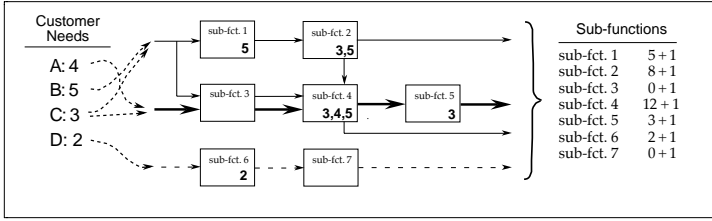

Figure 5. Schematic view of correlating customer needs to sub-functions to produce a customer need weighted product vector.

Once implemented, the normalized version of Φ , N , has elements

$$v_{ij} = \phi_{ij} \left(\frac{\bar{\eta}}{\eta_j} \right) \left(\frac{\mu_j}{\bar{\mu}} \right) \quad (1)$$

where the average customer need rating is

$$\bar{\eta} = \frac{1}{n} \sum_{i=1}^m \sum_{j=1}^n \phi_{ij} \quad (2)$$

the total customer need rating for the j th product is

$$\eta_j = \sum_{i=1}^m \phi_{ij} \quad (3)$$

the number of functions in the j th product is

$$\mu_j = \sum_{i=1}^m H(\phi_{ij}) \quad (4)$$

and the average number of functions is

$$\bar{\mu} = \frac{1}{n} \sum_{i=1}^m \sum_{j=1}^n H(\phi_{ij}) \quad (5)$$

where H is a Heaviside function, n is the number of products and m is the total number of different sub-functions for all products. Normalizing the Φ matrix provides a level playing field on which to compare products. The averaging and scaling technique defined above is an intuitive way to account for

variations in customer needs and functional models. We may now use this representation to determine the critical functions across the domain or any sub-domain of products. For our purposes of comparing functional models of the same product by different designers, we pre-multiply N' by its transpose to generate the similarity matrix as follows:

$$\Lambda = N'^T N' \quad (6)$$

where the elements represent the similarity or commonality of important functions that functional models share. Note that N' is the normalized product matrix where its columns are again normalized to unity for convenience (in terms of comparing two functional models). A value of one indicates two functional models are completely similar and a value of zero indicates they are completely dissimilar.

The formation of a product vector (to produce Φ and eventually Λ) is dependent on the assignment of customer need weights to sub-functions. That assignment is inherently subjective, so we compute the sensitivity of the Λ matrix to changes in the initial customer need weight assignments. The sensitivity of Λ to a change in initial customer need rating of one point is identified as ϵ in the results that follow and, in general, show a change only in the second decimal place of Λ elements.

4.3.2 Experimental Results

The product vector for the control functional model of the Nerf® ball blaster is shown in Table 9. The 21 functional models from the participants are aggregated together to form the Φ matrix, as described in the previous section. It is normalized and the similarity matrix is calculated using equation 6.

Table 9. Product vector for the control functional model of the Nerf® Ball Blaster.

Sub-function	CN value	Sub-function	CN value
convert he to me	6	import human	8
convert pe to me	1	import solid	6
convert me to pe	6	indicate status	1
display signal	1	regulate solid	1
distribute em	4	secure solid	6
distribute me	4	stabilize me	1
export em	4	stop gas	1
export gas	1	store gas	1
export human	1	store me	1
export solid	6	store solid	6
guide gas	1	supply gas	1
guide solid	1	supply me	1
import em	4	transmit me	1
import gas	1	transmit pe	6
import he	15		

The results comparing participants with the control functional model are shown in Table 10. The results demonstrate that the functional modeling derivation method allows designers to find virtually all of the customer need based important sub-functions. The sensitivity calculation, also shown in Table 10, further demonstrates that the similarity values are significant to the third decimal place.

Table 10. Similarity results of the participant functional models when compared against the control.

ID	λ	ϵ
Control	1	-0.01
14	0.9219	-0.0101
11	0.9186	-0.0104
9	0.9157	-0.0098
2	0.8746	-0.0098
8	0.8611	-0.0103
16	0.8602	-0.0097
12	0.8553	-0.0099
21	0.8366	-0.0111
4	0.8256	-0.0106
13	0.8176	-0.0103
15	0.8157	-0.0107
5	0.814	-0.0117
6	0.8099	-0.0106
20	0.8002	-0.0115
1	0.7992	-0.0103
10	0.7969	-0.0111
19	0.793	-0.0106
3	0.7544	-0.0095
17	0.7502	-0.0113
18	0.7489	-0.0109
7	0.6805	-0.0114

For the original design experiment, i.e. experiment 3, similar calculations are made. The control product vector is shown in Table 11 and the similarity results for the participants functional models when compared against the control are shown in Table 12. The similarity values are not as high for the original design experiment as they are for the existing product experiment. However, they do indicate that the derivation method does lead designers to identify a significant number of important functions for an original design (when no form is specified). This is extremely encouraging and viewed as a significant confirmation of the functional model derivation method.

Table 11. Product vector for the control functional model of the human powered generator.

Sub-function	CN value	Sub-function	CN value
actuate me	1	import human	10
change me	1	import solid	5
change ee	6	indicate status	1
convert he to me	6	secure solid	4
convert me to ee	6	separate solid	5
couple solid	8	stabilize me	5
distribute ae	5	store me	6
distribute me	3	supply me	1
export human	1	transmit ee	6
export solid	1	transmit me	1
import he	6		

Table 12. Similarity results of the participant functional models when compared against the control for the human powered generator.

ID	λ	ϵ
Control	1	-0.00444
9	0.72863	-0.0027
15	0.7242	-0.00408
20	0.69666	-0.00358
11	0.68254	-0.00242
14	0.6616	-0.00409
16	0.65071	-0.00396
19	0.64933	-0.00453
21	0.63372	-0.00256
13	0.6144	-0.00243
2	0.59689	-0.00254
6	0.55608	-0.00183
12	0.55528	-0.00216
3	0.50621	-0.00209
7	0.50392	-0.00279
10	0.50044	-0.00224
18	0.49883	-0.00557
8	0.49555	-0.00284
4	0.48883	-0.00269
1	0.46249	-0.00222
5	0.45005	-0.00118
17	0.42547	-0.00387

Table 13. Excerpt From the Nerf® Ball Blaster Adjacency Matrix.

Experiment #2		Sub-functions						
		...	Import em	Import gas	Import he	Store gas	Store solid	...
Inputs			10,10,10,10, 10,10,10,10, 10,10,10,8, 10,10	7,7,7,7,7, 7,7,7,7,7, 7,7,7				
Outputs	...							
	Guide Gas					7,7,7,7,7, 7,7		
	Guide Solid						1,1,1,5,1, 5,1,1,1,1, 5	
	...							

4.4 Topological Repeatability of Functional Modeling

In this section, the topology of the functional models is evaluated. By topology, we are referring to the specific flow connections between sub-functions of the functional model. In the previous section only the sub-function space was evaluated, but in order to test the correctness of the functional models they must be evaluated topologically. First, the functional models created in experiments 2 and 3 are entered into an adjacency matrix. The adjacency matrix will allow us to compare the functional models without a dependence on the spatial orientation [26].

The control functional model, for each experiment, is entered into its own adjacency matrix. Next, all of the functional models are entered into the adjacency matrix and then combined into a frequency adjacency matrix. Shown in Table 13 is a fraction of the frequency adjacency matrix for the Nerf® Ball Blaster.

The frequency adjacency matrix is read by starting at the row and reading over to the specified column. The flow, represented by a code in the cell ij , originates from the sub-function listed for that row i and enters the specific sub-function listed for the column j . Different numbers represent the flows in the frequency adjacency matrix. For example, in Table 13, flow 10, which refers to electro-magnetic energy, enters the system into the sub-function *import em*. This process is then repeated until all of the functional models are entered. If all of the functional models were identical, there would be all tens in the *import em* cell. As Table 13 shows, all of the flows that input into *import em* are not the same.

In order to display this information in a more understandable context, a modification to the frequency adjacency matrix is made. Table 14 and 15, on the following pages, shows this modification of the frequency adjacency matrix for experiments 2 and 3 respectively. In this matrix, only the sub-functions used in the control functional model are displayed. Each cell in the matrix displays the flows and the percentage of subjects who have the same flow connections. For example, if only three of the 21 subjects identified flow 5, which represents *human energy*, into the sub-function *import human energy*, this would be displayed as “5: 14.29%”. The cells that are highlighted follow the flows used in the control

functional model, and the specific flows contained in the control are bolded. The table also displays flow connections that are used incorrectly. As the data shows, there are discrepancies between the control functional model and the test subjects’ functional models. The results from experiment 2, however, are the most encouraging. From experiment 2, sub-functions such as *import em*, *import he*, *import human*, and *import solid* all show a high percentage of identification. *Export solid* also shows a high percentage of identification, but seems to be the only output that was consistently identified. Unfortunately, sub-functions such as *supply gas*, *secure solid*, and *transmit me* were not identified.

The results from experiment 3 are less encouraging than the results from experiment 2. There is a high percentage of identification of the *import human*, *import solid*, and *stabilize me* sub-functions. Unfortunately, no other flow connections were identified by more than 28.57 percent of the test subjects. In fact 16 connections that were contained in the control were not identified by any of the test subjects. One possible reason for this apparent lack of repeatability is the difficulty of creating a functional model for an original design. One must remember that many of test subjects participating in this experiment are new to functional modeling and have not completely learned the skills required to complete such a difficult task. Also, the control functional model (in both experiment 2 and 3) was generated by designers with a great deal of functional modeling experience.

5 CONCLUSIONS

5.1 Statistically Speaking

Two different measures recorded from the repeatability experiments are used to make inferences about the repeatability of the functional model derivation method, similarity and percent of sub-functions correctly identified. First, the data is checked for normality. Since the sample size of this experiment is small, the Shapiro-Wilk’s Test is used to test for normality in the data [29]. As a second check, a normal probability plot is created for all of the data. Both tests indicate the data is normal.

Table 14. Adjacency matrix for experiment 2.

Experiment #2		Sub-Functions																				Outputs											
		convert he to me	convert me to pe	convert pe to me	display signal	distribute em	distribute me	export em	export gas	export solid	guide gas	guide solid	import em	import gas	import he	import human	import solid	indicate status	regulate solid	secure solid	stabilize me		stop gas	store gas	store me	store solid	supply gas	supply me	transmit me	transmit pe			
Inputs		5: 4.76 8: 4.76			8: 19.1 11: 4.76	8: 9.52 10: 9.52	8: 0.00				3: 4.76 7: 4.76	10: 61.9 8: 4.76	7: 61.9	5: 90.48	2: 95.24 5: 14.29 2: 9.52 8: 14.29 5: 19.05 3: 4.76	1: 100.0	8: 0.00		3: 4.76	3: 14.29									3: 9.52				
Sub-Functions	convert he to me		3: 4.76								3: 9.52								5: 4.76				3: 19.05					3: 9.52 5: 4.76	2: 9.52 6: 4.76				
Sub-Functions	convert me to pe																											9: 19.05	2: 4.76 3: 4.76 7: 4.76				
Sub-Functions	convert pe to me																											3: 4.76	2: 4.76				
Sub-Functions	display signal																												8: 0.00				
Sub-Functions	distribute em																												6: 9.52 8: 23.81 10: 33.3				
Sub-Functions	distribute me	2: 4.76																											6: 9.52 1: 9.52 2: 14.29 3: 4.76 4: 9.52 8: 4.76 10: 9.52				
Sub-Functions	export em																												10: 9.52				
Sub-Functions	export gas																												7: 9.52 4: 4.76 5: 4.76				
Sub-Functions	export solid																												1: 66.67 3: 33.33 7: 9.52 4: 9.52 8: 14.29 9: 4.76				
Sub-Functions	guide gas																																
Sub-Functions	guide solid																													1: 23.81 2: 4.76 3: 14.29 4: 9.52 7: 14.29			
Sub-Functions	import em																																
Sub-Functions	import gas																																
Sub-Functions	import he	5: 11.9																															
Sub-Functions	import human	2: 4.76 5: 4.76																															
Sub-Functions	import solid																																
Sub-Functions	indicate status																																
Sub-Functions	regulate solid																																
Sub-Functions	secure solid																																
Sub-Functions	stabilize me	5: 4.76																															
Sub-Functions	stop gas																																
Sub-Functions	store gas																																
Sub-Functions	store me																																
Sub-Functions	store solid																																
Sub-Functions	supply gas																																
Sub-Functions	supply me																																
Sub-Functions	transmit me																																
Sub-Functions	transmit pe																																

Flow Legend					
1	Solid	6	Thermal Energy (te)	11	Target
2	Human	7	Gas	12	Electrical Energy (ee)
3	Mechanical Energy (me)	8	Signal	13	Chemical Energy (ce)
4	Acoustical Energy (ae)	9	Pneumatic Energy (pe)		
5	Human Energy (he)	10	Electromagnetic (em)		

Table 15. Adjacency matrix for experiment 3.

Experiment #3		Sub- Functions																	Outputs									
		actuate me	change ee	change me	convert he to me	convert me to ee	couple solid	distribute ae	distribute me	export ee	export human	export solid	import he	import human	import solid	indicate status	secure solid	separate solid		stabilize me	store me	supply me	transmit ee	transmit me				
Inputs		3: 4.76 8: 4.76			5: 9.52		1: 9.52 5: 9.52		3: 9.52 5: 4.76				5: 28.57 8: 9.52 2: 4.76	2: 119.1 5: 9.52 8: 4.76	1: 57.14 2: 19.05 3: 23.81 5: 33.33 8: 0.52	10: 4.76		1: 9.52 2: 9.52 3: 9.52 5: 4.76		3: 42.86								
Sub- Functions	actuate me					3: 4.76										8: 0.00				3: 4.76	3: 0.00						6: 0.00	
	change ee																						12: 4.76					
	change me					3: 9.52	3: 0.00													3: 0.00	3: 9.52							6: 0.00
	convert he to me			3: 4.76		3: 33.33 8: 4.76	2: 4.76	3: 0.00		2: 4.76											3: 4.76						3: 4.76 8: 0.00	2: 19.05 3: 4.76 4: 23.81 5: 4.76 6: 19.05
	convert me to ee		12: 4.76					12: 0.00									8: 4.76 12: 4.76						12: 14.29					3: 9.52 4: 28.57 6: 9.52
	couple solid																1: 9.52 3: 0.00 2: 19.05 5: 4.76	1: 0.00 3: 0.00					1: 4.76 12: 4.76					1: 4.76 2: 4.76 4: 9.52 5: 9.52 6: 4.76 8: 4.76 12: 4.76
	distribute ae																											6: 4.76 8: 4.76
	distribute me				2: 9.52																3: 4.76						3: 4.76 5: 4.76	3: 28.57 1: 14.29 4: 14.29 6: 28.57 8: 4.76
	export ee																											12: 24 8: 4.76
	export human									2: 4.76 5: 4.76																		2: 14.3 5: 4.76
	export solid										2: 4.76 5: 4.76																	1: 4.76 2: 9.52 3: 4.76
	import he				5: 7.41 8: 0.00 3: 0.00		5: 9.52		5: 4.76								5: 4.76			5: 4.76							1: 4.76 2: 4.76	2: 4.76
	import human				2: 14.29		2: 14.29		2: 14.29	2: 0.00		2: 4.76		2: 14.29		2: 14.29 5: 9.52			2: 19.05 3: 4.76 5: 4.76							2: 14.29	2: 4.76	
	import solid				1: 4.76 3: 4.76		1: 7.14 2: 4.76 3: 9.52 5: 9.52		1: 4.76 3: 4.76					1: 14.29 2: 14.29 3: 4.76 5: 14.29						1: 4.76						1: 4.76	1: 4.76 3: 4.76	
	indicate status																											8: 11.9 1: 4.76 2: 4.76 3: 4.76 10: 4.76 12: 4.76
	secure solid						1: 4.76		1: 4.76 3: 9.52								1: 4.76 2: 4.76 5: 4.76	2: 4.76	1: 4.76 2: 19.05					2: 4.76		1: 0.00 3: 0.00	1: 19.05 2: 19.05 3: 23.81 4: 4.76 5: 4.76 6: 9.52	
	separate solid									2: 4.76	1: 4.76 2: 4.76						8: 0.00											3: 4.76 1: 4.76 2: 14.29
	stabilize me																											3: 9.52
	store me		3: 0.00 8: 0.00			3: 9.52	3: 0.00														8: 4.76							2: 4.76 6: 4.76 4: 4.76
supply me																											3: 0.00	
transmit ee			12: 0.00			3: 0.00				12: 9.52										12: 4.76							1: 9.52 2: 4.76 3: 4.76 4: 4.76 8: 4.76 12: 4.76	
transmit me			3: 4.76		3: 0.00			3: 9.52			1: 0.00																3: 7.14 1: 4.76 2: 19.05 5: 14.29	

Flow Legend					
1	Solid	6	Thermal Energy (te)	11	Target
2	Human	7	Gas	12	Electrical Energy (ee)
3	Mechanical Energy (me)	8	Signal	13	Chemical Energy (ce)
4	Acoustical Energy (ae)	9	Pneumatic Energy (pe)		
5	Human Energy (he)	10	Electromagnetic (em)		

Table 16. Experiment #2 and #3 Statistical Inferences.

	Mean	Confidence Interval	Prediction Interval
Experiment #2			
Similarity	0.8214	(0.7939, 0.8489)	(0.6923, 0.9504)
% Sub-Functions Identified	40.39	(35.33, 45.46)	(16.63, 64.15)
Experiment #3			
Similarity	0.5753	(0.5318, 0.6188)	(0.3713, 0.7794)
% Sub-Functions Identified	35.50	(29.10, 41.90)	(5.488, 65.51)

In order to determine if there is an improvement in the subjects' ability to identify sub-functions from experiment 1 to experiment 2, a *t* test for dependent means is performed. Performing a *t* test will determine if the differences between the two means of experiment 1 and 2 are by chance, or due to a real difference between the means. When the *t* test between experiment 1 and 2 is performed, there is a significant difference ($p = 0.0001$). Therefore it is concluded that when the functional model derivation method is applied to the Nerf® Ball Blaster, the test subjects are able to identify more of the correct sub-functions because of the functional model derivation method.

Looking at Table 16 for experiment 2, a 95% confidence interval for μ , the true average similarity for the population similar to those tested is (.7939, .8489), and a prediction interval for the similarity of any one randomly chosen from the population is (0.6923, 0.9504). A 95% confidence interval for μ , the true average percent of sub-functions identified for the population similarity to those tested is (35.33, 45.46), and a prediction interval for the percent sub-functions of any one randomly chosen from the population is (16.63, 64.15). For example, at the 95% confidence level, as few as 16.63% or as many as 64.15% of the sub-functions of the Nerf® Ball Blaster could be identified by a subject, similar to those who participated in this test, using the functional model derivation method. The results for experiment 3 are similar to those obtained from experiment 2, as shown in Table 16.

In order to determine if these conclusions would be consistent with other products, more experiments testing the functional model derivation method on other products need to be conducted. The results from these tests then need to be compared to each other to determine if the functional model derivation method gives more repeatable results for other products. These results are, however, encouraging at this point.

5.2 General Thoughts

This experimental study leads us to make conclusions in four areas.

- Clarity in communication is increased by the functional basis vocabulary. The functional derivation method definitely improves the clarity with which designers can communicate product function. This fact is borne out by a simple comparison of percent of sub-functions identified correctly between experiment 1 and 2. It is also shown to be a statistical fact by the *t* test.

- Specifying a level of detail improves repeatability, as shown between experiment 1 and 2. The experiments also show that specifying a level of detail leads to functional models with more sub-functions, indicating that the functional modeling derivation method generates more complete functional models.

- Deriving a functional model is repeatable for redesign and original design cases. Although the results of the original design case (experiment 3) are slightly lower than the case of the existing product, they do show a significant measure of repeatability.

- Flow connectivity is not repeatable at this point. While the adjacency matrix shows some flow connections are repeated (up to 100% frequency), few have a frequency over 20%. It is possible that the adjacency matrix is not the best metric for flow connectivity repeatability, as one simple permutation of a function chain will show as incorrect. This is an area for future work.

Overall, the functional modeling derivation method significantly improves repeatability. Our research leads us to conclude that achieving *identical* functional models between different designers may not be realistic. However, the functional model derivation method will significantly improve the repeatability of functional models, both in terms of percent of sub-functions correct and customer need weighted sub-functions, among even functional modeling novices.

ACKNOWLEDGEMENTS

This work is supported by the National Science Foundation under grant DMI-9988817, Ford Motor Company, Desktop Manufacturing Corporation, Texas Instruments, W.M. Keck Foundation, the June and Gene Gillis Endowed Faculty Fellow in Manufacturing and the University of Missouri-Rolla Intelligent Systems Center. Any opinions or findings of this work are the responsibility of the authors, and do not necessarily reflect the views of the sponsors or collaborators.

REFERENCES

- [1] McAdams, D., Wood, K., 2000, "Quantitative Measures For Design By Analogy," *Proceedings of DETC2000*, DETC2000/DTM-14562, Baltimore, MD.
- [2] Stone, R., Wood, K., and Crawford, R., 2000a, "Using Quantitative Functional Models to Develop Product Architectures," *Design Studies* 21(3):239-260.

- [3] Stone, R., Wood, K., and Crawford, R., 2000b, "A Heuristic Method for Identifying Modules for Product Architectures," *Design Studies*, 21(1):5-31.
- [4] Dahmus, J., Gonzalez-Zugasti, J., Otto, K., 2000, "Modular Product Architecture" *Proceedings of DETC2000*, DETC2000/DTM-14565, Baltimore, MD.
- [5] Pahl, G. and Beitz, W., 1996, *Engineering Design: A Systematic Approach*, 2nd ed., Springer-Verlag.
- [6] Kirschman, C., Fadel, G., 1998, "Classifying Functions for Mechanical Design," *Journal of Mechanical Design, Transactions of the ASME*, 120(3):475-482.
- [7] Hundal, M., 1990, "A Systematic Method for Developing Function Structures, Solutions and Concept Variants," *Mechanism and Machine Theory*, 25(3):243-256.
- [8] Hubka, V. and Eder, W. E., 1984, *Theory of Technical Systems*, Springer-Verlag, Berlin.
- [9] Murdock, J., Szykman, S. and Sriram, R., 1997, "An Information Modeling Framework to Support Design Databases and Repositories," *Proceedings of DETC'97*, DETC97/DFM-4373, Sacramento, CA.
- [10] Lai, K., and W. R. D. Wilson, 1989, "FDL - A Language for Function Description and Rationalization in Mechanical Design," *Journal of Mechanics, Transmissions, and Automation in Design*, 111:117-123.
- [11] Iwasaki, Y., M. Vescovi, R. Fikes, and B. Chandrasekaran, 1995, "Casual Functional Representation Language with Behavior-Based Semantics," *Applied Artificial Intelligence*, 9:5-31.
- [12] Umeda, Y. and T. Tomiyama, 1997, "Functional Reasoning in Design," *IEEE Expert Intelligent Systems and Their Applications*, 12(2):42-48.
- [13] Miles, L., 1972, *Techniques of Value Analysis Engineering*, McGraw-Hill, New York, NY.
- [14] Akiyama, K., 1991, *Function Analysis: Systematic Improvement of Quality Performance*, Productivity Press, Cambridge, MA.
- [15] VAI (Value Analysis Incorporated), 1993, *Value Analysis, Value Engineering, and Value Management*, Clifton Park, New York, NY.
- [16] Collins, J., Hagan, B., and Bratt, H., 1976, "The Failure-Experience Matrix - a Useful Design Tool," *Transactions of the ASME, Series B, Journal of Engineering in Industry*, 98:1074-1079
- [17] Modarres, M., 1997, "A Functional Classification Based on Conservation Principles," *Proceedings of the Fifth International Workshop on Functional Modeling of Complex Technical Systems*, Paris-Troyes, France.
- [18] Amoussou, G., Vicarini, M., Rohmer, S., Barros, L., 1997, "Application of TROPOS Functional Model to a Maintenance System of a Nuclear Plant," *Proceedings of the Fifth International Workshop on Functional Modeling of Complex Technical Systems*, Paris-Troyes, France.
- [19] Vicarini, M., 1995, "Mesurer pour simplifier", *L'Informatique Professionnelle*, Paris, France.
- [20] Szykman, S., Racz, J., Sriram, R., 1999, "The Representation of Function in Computer-Based Design", *Proceedings of the ASME Design Theory and Methodology Conference*, DETC99/DTM-8742, Las Vegas, NV.
- [21] Stone, R. and Wood, K., 2000, Development of a Functional Basis for Design, *Journal of Mechanical Design*, 122(4):359-370.
- [22] Hirtz, J., Stone, R., McAdams, D., Szykman, S. and Wood, K., 2001, "Evolving a Functional Basis for Engineering Design," *Submitted to Proceedings of DETC2001, DTM Conference*.
- [23] Antonsson, E., 1987, "Development and Testing of Hypotheses in Engineering Design Research", *Journal of Mechanisms, Transmissions, and Automation in Design*, 109(2):153-154.
- [24] Otto, K., 1996, "Forming Product Design Specifications," in *Proceedings of the 1996 ASME Design Theory and Methodology Conference*, DETC96/DTM-1517, Irvine, CA.
- [25] Otto, K. N. and K.L. Wood, 2000, *Product Design: Techniques in Reverse Engineering, Systematic Design, and New Product Development*, Prentice-Hall, NY.
- [26] Kurfman, M., Stone, R., Van Wie, M., Wood, K., Otto, K., 2000, "Theoretical Underpinnings of Functional Modeling: Preliminary Experimental Studies," *Proceedings of DETC2000*, DETC2000/DTM-14563, Baltimore, MD.
- [27] McAdams, D., Stone, R., and Wood, K., 1999, "Functional Interdependence and Product Similarity based on Customer Needs," *Research in Engineering Design*, 11(1):1-19.
- [28] McAdams, D., Stone, R., and Wood, K., 1998, "Product Similarity Based on Customer Needs," *Proceedings of DETC98*, DETC98/DTM-5660, Atlanta, GA.
- [29] Shapiro, S., 1980, *Volume 3: How to Tell Normality and Other Distributional Assumptions*, American Society for Quality Control, Milwaukee, WI.