

To Appear in *Design Studies*.

A HEURISTIC METHOD FOR IDENTIFYING MODULES FOR PRODUCT ARCHITECTURES

Robert B. Stone
Department of Basic Engineering
University of Missouri-Rolla
Rolla, MO 65409-0210
rstone@umr.edu

Kristin L. Wood and Richard H. Crawford
Department of Mechanical Engineering
The University of Texas at Austin
Austin, TX 78712
wood@mail.utexas.edu, rhc@mail.utexas.edu

A HEURISTIC METHOD FOR IDENTIFYING MODULES FOR PRODUCT ARCHITECTURES

Abstract

Developing product architectures is a key phase in design and development processes. It encompasses the transformation of product function to alternative product layouts. In this paper, we describe a new approach for identifying modules for product architectures. We begin by reviewing the terminology and motivation for modular products. The new concepts of a functional basis and time ordered function chains are used to formally derive functional models of products. Then, three heuristic methods for identifying modules from functional models are presented. Using the formal functional decomposition and heuristic methods, modular design can be executed earlier in the product development process, as illustrated by the example of a consumer power-tool product and a larger, complex maintenance device. A database of 70 consumer products is used to verify and confirm the overall modular design approach.

Keywords: design methodology, product development, conceptual design, functional modeling

Modules are defined as physical structures that have a one-to-one correspondence with functional structures¹. Modular products may be defined as machines, assemblies or components that accomplish an overall function through combination of distinct building blocks or modules². While modular products have distinct manufacturing advantages in many instances, modularity in mechanical design is often an afterthought. Once a product is designed and developed, components of the product are observed to have other potential uses. Effective application of these components as modules can lead to faster development and reduced costs in future product designs. However, if modularity is identified and exploited in the initial conceptual or reverse engineering effort, the *immediate* product design reaps benefits in reduced development time and costs^{3,2}. (Reverse engineering initiates the redesign process, wherein a device is predicted, observed, disassembled, analyzed, tested, “experienced,” and documented in terms of its functionality, form, physical principles, manufacturability and assemblability⁴).

Combining components or modules into complete products is addressed in recent work on automated design techniques^{5,6,7,8,9,10}. Likewise, significant advancements have been made in integrating components or reducing part count at the form-level of design^{11,12,13,14,15,16,17}. However, how do we define what the function of a module is? How do we define appropriate module interfaces and opportunities? Both Cutherell¹⁸ and Ulrich and Eppinger¹ present a four step process for defining a module-based product architecture. This process begins by decomposing a product into functional schematics, then defining “chunks” as possible modules. Yet, the process lacks a systematic technique for clustering elements and defining interactions. The heuristic methods in this paper provide such a technique. Once modules are defined, alternative layouts and component selection become more straightforward tasks. Economic tradeoffs may then be applied to the alternatives, using, for example, Krishnan et al.’s¹⁹ model of product development costs for modular products.

In the next sections, we present a novel heuristic method to identify modules as part of an overall product architecture design methodology.

1 AN OVERVIEW OF PRODUCT ARCHITECTURE DESIGN

Product architecture design is, in its essence, the transformation from product function to product form. It relies upon successful gathering of customer needs and their mapping to a functional model of the product. After that, though, a choice must be made about the type of product architecture to implement – integral vs. modular. An integral architecture is defined as a physical structure where the functional elements map to a single or very small number of physical elements¹⁸. Examples of integral products are shown in Fig. 1. Modular architectures, on the other hand, are physical product sub-structures that have a one-to-one correspondence with a subset of a product's functional model. Examples of modular architectures are shown in Fig. 2. Next, we present a design methodology which identifies possible modular product architectures.

An overview of our product architecture design methodology is shown in Fig. 3. Step 1: Gather Customer Needs and Steps 4 - 5: Generate Concepts and Embody Design are well documented in literature^{1, 2, 33, 20, 21, 22} and are not the focus of this article. Instead, identifying modular product architectures (Step 3) is our focus. We take a function based approach to defining modules in this work, believing that good design begins only after a thorough understanding of product function. Therefore, the next section addresses the issues of Step 2, i.e. how to derive functional models of products and how to do so in a manner that imposes more order on the functional model.

2 FUNCTIONAL MODELING

Functional modeling, also known as functional decomposition, is the process of breaking the overall function of a product into smaller, easily solvable sub-functions. The sub-functions are related by the *flow* of energy, material or signal passing through the product to form a functional model, known as a function structure. Pahl and Beitz² provide an overview for such a functional decomposition process. The module heuristics presented in the following section require an additional level of formalism in functional models. Therefore, we present the more structured approach of Step 2 (in Fig. 3) to derive a functional model.

2.1 Generate Black Box model

The first task of the functional model derivation is to create a Black Box model, a representation of a product's overall function and input/output flows. The overall function of the product is expressed in verb-object form. This task relates the customer needs from Step 1 to the functional model. Each customer need identifies one or more input or output flows for the product. These flows, in turn, directly address the specific customer need. In general, customer needs only identify input or output flows, not flows internal to the product. An example Black Box model for a consumer power screwdriver is shown in Fig. 4.

2.2 Create function chains for each input flow

For each input flow, Task 2 develops a chain of sub-functions that operate on the flow. Here, the designer must 'become the flow.' Think of each operation on the flow from entrance until exit of the product (or transformation to another flow) and express it as a sub-function in verb-object form. If a flow is transformed to another type, then follow the operations on the transformed flow until it exits the product. Examples of two function chains for the power screwdriver are shown in Fig. 5. In Fig. 5 (a), a function chain for the flow *electricity* is developed. By 'becoming the flow,' the designer realizes that five sub-functions operate on *electricity* before it is converted to *torque*. Four additional sub-functions then act on *torque* before it exits the product boundary.

2.2.1 Express sub-functions in a common functional basis

The function chains (and the subsequent functional model) are expressed in a standard vocabulary known as a functional basis^{23,24}. The functional basis is a set of functions and flows with clear definitions that are combined in verb-object form to describe a sub-function (shown in Tables 1 & 2). In general, the basis functions and flows are broken into classes (eight function classes and three flow classes) and then further specified within each class as basic or sub-basic. The energy flows in Table 2 offer increased detail through the use of complements based on power conjugate variables of bond graph models²⁵. Functions from Table 1 fill the verb position of the verb-object sub-function description, while flows from Table 2 provide the object. Expressing a functional model in functional

basis form provides the general benefit of repeatable function structures among different designers. Furthermore it offers a standard level of detail for functional models. These two attributes have been the goal of early value engineering work^{26,27} as well as recent functional modeling research^{23,24,28,29,30}. We refer the reader to recent work on functional modeling by Little et al.²³, McAdams et al.³¹, and Stone²⁴ for more information.

2.2.2 Order function chains with respect to time

In addition to the use of a functional basis, the functional model is ordered with respect to time. Traditional decomposition techniques, like the Pahl & Beitz method, trace flows through sub-functions without regard for the dependence of sub-functions on a specific order. Ulrich & Eppinger¹, though, note that task dependencies for product development processes are either parallel, sequential or coupled with respect to time. Here we extend the concept of parallel and sequential dependencies to sub-functions and flows of a functional model. In each case, the dependencies are defined with respect to a given flow.

In *sequential function chains*, the sub-functions must be performed in a specific order to generate the desired result. A flow common to all these functions is termed a *sequential flow*. For the power screwdriver, the flow *electricity* produces a sequential function chain in Fig. 5 (a). Here, five sub-functions must operate on the flow of electricity in a specific order to obtain the desired result of usable electrical energy.

Parallel function chains consist of sets of *sequential function chains* sharing one or more common flows. Graphically, they are represented by a flow which branches in a functional model. Collectively, the chains are called *parallel* because they all depend on a common sub-function and flow, but are independent of each other. Independence means that any one of the chains of the parallel function chain set does not require input from any other chain within the set. Physically, the parallel function chains represent different components of a device that may operate all at once or individually. Figure 5 (b) shows an example of a parallel function chain for the power screwdriver. In it, the flow *human force* branches to form parallel chains of sub-functions. The four chains operate independent of each other

(the first is concerned with the insertion and removal of the screw bit, the second deals with the manual use of the screwdriver, the third transmits the weight of the product and the fourth actuates the device).

2.3 Aggregate function chains into a functional model

The final task of functional model derivation is to aggregate all of the function chains from Task 2 into a single model. It may be necessary to connect the distinct chains together. This action may require the addition of new sub-functions. Also, if different flows are operated on by the same sub-functions, then the chains may be combined to show two flows traversing the chain of sub-functions. The aggregated functional model for the previously discussed power screwdriver is shown in Fig. 6. Note that both function chains from Fig. 5 are present and that links between flows of *bit* and *screw* are added. Also, the actuate electricity leg of the *human force* parallel chain is combined with the *electricity* sequential chain.

The result of Step 2 of the methodology is a functional model of a product. It has uses beyond the product architecture application reported here. With a functional model expressed in the functional basis, functions may be directly related to customer needs, products and their functional representations may be directly compared, product families may be identified, product functions may be prioritized, and direct component analogies may be generated within and outside product classes.

3 THE METHOD OF MODULE HEURISTICS

The method of module heuristics consists of three separate strategies to identify modules. The necessary starting point is a well refined functional model as derived in the previous section. Consider our approach to heuristic module identification. Webster's dictionary defines a heuristic as "a method of education or of computer programming in which the pupil or machine proceeds along empirical lines, using rules of thumb, to find solutions or answers." Here is our working definition of module heuristics: A method of examination in which the designer uses a set of steps, empirical in nature, yet proven scientifically valid, to identify modules in a design problem. This definition requires

another: the phrase “proven scientifically valid” refers to a hypothesis, formulated after systematic, objective data collection, that has successfully passed its empirical tests. Thus, the heuristics are proven by following the scientific method.

Briefly, the module heuristics grew out of a design of a large scale maintenance device. In the conceptual design phase, groups of sub-functions related by flows were observed to form subsystems or modules of the device. This observation led to the formulation of three heuristics to identify modules based on the three possibilities that a flow can experience: 1) a flow may pass through a product unchanged, 2) a flow may branch, forming independent function chains, or 3) a flow may be converted to another type. The heuristics were empirically verified with a set of hand-held consumer mechanical and electromechanical devices. The verification procedure is detailed in Section 4.

We introduce three heuristic methods below as developed from these observations and definitions. These methods offer surprisingly elegant definitions of modules from function structures. However, each of the methods may identify overlapping modules or modules which are subsets or supersets of other modules. The choice of which module to implement in that case is not always clear. The rule suggested here is to implement the module with the smaller number of sub-functions. This idea is in keeping with the philosophy that modules should be easily identifiable with a particular function. Ultimately, though, which module to implement requires some engineering judgment.

As the three heuristics are introduced, a functional model of a SKIL Twist power screwdriver is used as a physical example. The power screwdriver was chosen for the example series because it deals with several material flows. Some of the modules identified by the heuristics appear as modules in the current product and others offer areas for future modularity. The functional models were generated by the reverse engineering method of Otto and Wood⁴ and the functional model derivation step of the previous section. We show the identified modules in the power screwdriver for each heuristic, discuss which ones exist and which ones present opportunities for a more modular design.

3.1 Dominant Flow

The dominant flow heuristic examines each non-branching flow of a function structure and groups the sub-functions the flow travels through until it exits the system or is transformed into another flow. The identified set of sub-functions defines a module that deals with the flow traced through the system. The identified sub-functions form the boundary, or *interface*, of the module. Any other flows, in addition to the traced flow, that cross the boundary are *interactions* between the module and the remaining product. A dominant flow module is shown schematically in Fig. 7. To implement the module, conduits must be specified to carry the interactions across the interface.

Stated succinctly, the dominant flow heuristic is:

Heuristic 1: The set of sub-functions which a flow passes through, from entry or initiation of the flow in the system to exit from the system or conversion of the flow within the system, define a module.

Screwdriver - Identified modules

In the SKIL Twist power screwdriver, the flow *electricity* passes through five sub-functions as outlined by a dashed rectangle shown in Fig. 8. The sub-functions *store electricity*, *supply electricity*, *transmit electricity*, *actuate electricity* and *regulate electricity* all operate on the flow *electricity*. The dominant flow heuristic identifies that these sub-functions could be combined as one module, which we name the *supply electricity module*.

The next flow to trace is the *bit*. It first enters the system and traces through the two sub-functions *couple solid* and *secure solid*. This set of sub-functions forms a module that we call the *coupling module*. The flow *hand* identifies a superset of the *coupling module* which also encompasses the separation of the bit from the device. The flow *torque* emerges from the *convert electricity to torque* sub-function and travels through the sub-functions *change torque*, *transmit torque*, *rotate solid* and *dissipate torque*. Here the heuristic identifies these four sub-functions as the *transmit torque module*.

For the power screwdriver, the dominant flow heuristic identifies four modules, one for each purely sequential function chain. Not all product function structures will have a module associated with every non-branching flow. In some instances, flows may enter only

one sub-function and then be transformed, thus never forming a sequential function chain. Next, we discuss how the identified modules compare with existing modules and how others offer opportunities for an improved modular design.

Screwdriver - Actual modules

The identified modules are now verified by checking the actual product. Actual modules will be referenced with respect to the exploded view shown in Fig. 9. The module associated with the flow of electricity is actually found as two modules in the SKIL Twist power screwdriver. The *store electricity* and *supply electricity* sub-functions are embodied by a rechargeable battery, while the *transmit electricity*, *actuate electricity* and *regulate electricity* functions form a switch module (to turn on as well as change the direction of the screwdriver). These two sub-modules are identified in Fig. 9 (b). In this sense, the heuristic method correctly identifies sub-functions that come together as modules. A possible product innovation, shown in Fig. 10, integrates the five sub-functions into a single component that stores, supplies, transmits, actuates and regulates electricity and interfaces with other drive units besides screwdrivers. The rechargeable battery solves the *store* and *supply electricity* sub-functions. The switch *transmits*, *actuates* and *regulates electricity*. With this concept, the *supply electricity module* would interface with different drive modules to create a mix modularity tool. For example, it could attach to a screwdriver, drill, detail sander or flashlight drive unit. This approach advances the modular battery powered hand tools available today a step further.

Predicted modules associated with the flows *bit*, *hand* and *torque* (*coupling*, *hand interface* and *torque transmission* modules, respectively) exist in the screwdriver as well. The *coupling* and *hand interface* modules are embodied by the same physical component – the shaft of the transmission in Fig. 9 (b). Note that the dominant flow method does not identify this module sharing opportunity, i.e., the possibility of a single, physical module to embody two or more module concepts. The *transmit torque* module is embodied by the transmission component.

Thus, the dominant flow heuristic method predicts modules that exist in the screwdriver. In addition, it provides an innovative way of combining functions into one component that could be shared among products. Another point to note about the dominant flow heuristic is that it defines functions that can be combined into assembly modules, i.e., parts that are best connected together before assembling the entire product.

3.2 Branching Flow

The second heuristic is referred to as “branching flow” and requires identification of flows associated with parallel function chains. Each limb of a parallel function chain defines a potential module and is shown schematically in Fig. 11. The module is formed of the sub-functions that make up the limb (technically, each limb consists of a sequential function chain). All modules (one per limb) must interface with the product at the flow’s branch point. All flows that cross this interface are the interactions between the remaining product and the module.

Note that branching flows will identify products capable of component swapping or bus modularity. Bus modularity describes a device with two or more interfaces that accepts any combination of components from a set with standard interfaces. Memory expansion slots in computers are an example of bus modularity. The interface boundaries defined are physical connections between module and product. In some cases they will be well-defined geometric connections, like various end mill attachments on a milling machine. Other times, the interface may be fuzzier, like the differing interactions between human force and the SKIL Twist power screwdriver.

The branching flow heuristic is stated formally as:

Heuristic 2: The limbs of a parallel function chain define constitute a modules. Each of the modules interface with the remainder of the product through the flow at the branch point.

Screwdriver - Identified modules

The power screwdriver has three flows that branch, the *bit*, *screw* and *human force*. The flow *human force* is examined first. Following the sub-function *import human force*, the flow branches into four limbs. Each limb represents a module as shown in Fig. 12. The four

identified modules are the *coupling/decoupling*, *manual use*, *actuating* and *weight transmission* modules. Note that a subset of the *coupling/decoupling* module was identified by the dominant flow heuristic. The *actuate* module is a subset of the *supply electricity* module identified by the dominant flow heuristic. The *manual use* and *weight transmission* modules are new.

The branching flow of bit identifies two possible modules: *decoupling* and *bit-transmission*. The *decoupling* module, together with the *coupling* module of the dominant flow heuristic, constitutes the *coupling/decoupling* module already identified. The *bit-transmission* module is a subset of a previously identified module.

The flow *screw* branches after the import solid sub-function and identifies two possible modules consisting of the rotate solid sub-function (one deals with manual use of the screwdriver and the other with powered use).

Screwdriver - Actual modules

The branching flow heuristic identifies three new modules (*coupling/decoupling*, *manual use* and *weight transmission* modules), in addition to several modules that overlap with the modules from the dominant flow heuristic. The *coupling/decoupling* and *bit-torque transmission* modules are embodied by the same component as the *coupling* and *torque-transmission* modules of the previous section. The *actuating* module is a subset of the *supply electricity* module. The *manual use* module is embodied by a locking mechanism which secures the screwdriver transmission in place. It is identified as the rotational lock in Fig. 9 (b). Also, the *weight transmission* module is essentially the plastic casing of the screwdriver.

A few remarks about the heuristics usage thus far are warranted. It is evident that they identify overlapping modules in some cases. At this point, we wonder which module to embody in such a case. Section 6 of this paper discusses extensions to this work, including a customer needs approach, which provide a means of determining which module to implement. For now, we make the observation that the more ways a module is identified (in terms of heuristics and flows), the more important it is to implement (since it must be associated with more customer needs).

3.3 Conversion-Transmission Modules

The third heuristic method deals with conversion sub-functions and conversion to transmission chains. Conversion sub-functions accept a flow of material or energy and convert the flow to another form of material or energy. In standard verb-object form, a conversion sub-function appears as *convert* flow A *to* flow B. In many cases, these conversion sub-functions are already components or modules themselves. For instance, electrical motors, hydraulic cylinders, and electrical heaters can all be represented by a single conversion sub-function and exist physically as a single component. If, additionally, a conversion sub-function exists in a chain with a transmit sub-function (or transport sub-function for material flow), then the chain presents an opportunity to form a module. This converts an energy or material to another form and then implements (transmits or transports) that new form of energy or material.

The method of the conversion-transmission heuristic, shown schematically in Fig. 13, is simple. The essential actions are as follows: identify conversion sub-functions and check for transmit or transport sub-functions downstream of the converted flow. If none exist, then the conversion sub-function is a module by itself. If transmit or transport sub-functions exist without any other sub-functions between them, then the convert-transmit (transport) pair represents a module. If other sub-functions exist between the convert and transmit (transport) sub-functions and those intermediate sub-functions only operate on the converted flow (i.e. the object in the sub-function verb-object pair is the converted flow), then the conversion-transmission (transportation) chain represents a module.

Interfaces of a conversion-transmission module are defined in a similar manner as those for a dominant flow module. Two necessary interactions across the interface are the flow to be converted and the exiting converted flow. Additional flows may also cross the interface.

The conversion-transmission heuristic, stated succinctly, is:

Heuristic 3: A conversion sub-function or a conversion-transmission pair or proper chain of sub-functions constitutes a module.

Screwdriver - Identified modules

Consider the power screwdriver again, the conversion-transmission heuristic identifies one module, as shown in Fig. 14. It consists of three sub-functions, the bounding *convert electricity to torque* and *transmit torque* and the intermediate sub-function *change torque*. The interface of the *electricity to torque* module is outlined in Fig. 14. The interactions are the two necessary flows of *electricity* and *torque*, along with *heat* and *coupled bit*.

Screwdriver - Actual modules

In the actual product, the three sub-functions are not embodied as a single module. The *convert electricity to torque* sub-function is a distinct component, i.e. the motor in Fig. 9 (b). The *change torque* and *transmit torque* sub-functions, though, are part of the *torque transmission module* previously identified and embodied by the transmission in Fig. 9 (b). In this case, the method provides an innovative approach to the design of a module that incorporates a motor, transmission, and drive-train. Recall the innovative *supply electricity module* of the screwdriver in Figure 10. In concert with the *supply electricity module*, the *electricity to torque module* becomes the drive unit in a mix and match set of power packs with switches and motor drive units.

4 VERIFICATION OF HEURISTIC METHODS

The three heuristic methods introduced in Section 3 are presented with the SKIL power screwdriver example. The heuristics were developed and verified more rigorously using a database of 70 products, of which the power screwdriver is a part²⁴. The products represent a wide range of consumer applications, customer needs, and overall functions. The mechanical or electromechanical products include small construction tools, small kitchen appliances, automobile accessories, small household appliances, and toys. This set of products represents over 100 person years of work in reverse engineering and redesign and is the same set used by Little et al.²³ and McAdams et al.³¹. The redesigns and case studies are the result of course work, research, and industrial interaction at The University of Texas at Austin and the University of Missouri at Rolla.

Of the 70 products, 18 are examined in detail in Table 3. The 18 products are representative of the wide range of consumer applications in the entire database. Two types of products, an iced tea brewer and a power screwdriver, are repeated (same type of product, different manufacturer) to examine the differences in competing products. All product function structures produce modules when the three heuristic methods are applied. The products are listed in column one followed by three columns that indicate the number of modules identified by each of the three heuristic methods: dominant flow, branching flow and conversion-transmission. The next three columns indicate the actual modules found in the products, associated with the three heuristic methods. Since it is possible for the different heuristic methods to identify overlapping modules, the final two columns give the number of unique modules possible and then the actual number of modules found in the product.

It is important to note from the final two columns of Table 3 that the number of unique modules possible is always greater than (or equal to for three of the products) the actual number of modules implemented in current products. This strongly supports the heuristic methods' validity as a tool to identify possible modules in a product. For this database of consumer, largely hand-held products, four to nine unique modules are possible. The actual products, though, incorporate between two to seven modules, with some exhibiting an impressive degree of modularity. For consumer products with 15 to 30 sub-functions, we now know that, on average, six unique modules are possible.

4.1 A More Complex Example

As a comparison, a large heavy-duty maintenance product – a lignite removal system for the power generation industry - is examined²⁴. A power generation plant in Texas (USA) produces electricity via a lignite fueled boiler. Lignite is best described as a dirty coal, and the dirtier the coal, the more residue produced during the burning process. Residue collects in the bottom of the boiler, known as the hopper. A cross sectional view of a typical boiler bottom is depicted in Fig. 15. This residue, called a clinker, is a glass-like substance that typically forms in large chunks, depending on the lignite quality. Clinkers must be removed

from the hopper periodically to maintain full power generation capability. Ideally, the grinder system, a set of rotating cylinders with protruding teeth, crushes the clinkers into smaller chunks that can be flushed out of the boiler. In practice, however, the clinkers are too large to enter the grinder and require fragmenting.

The power generation plant desired to develop a device, tele-robotic in nature, that can enter the hopper through an access door and fragment clinkers so that they can be removed by the grinder or flushed through the access door. Currently, clinkers are fragmented in a dangerous, manual operation. While the fragmentation process is carried out, the boilers must operate at a lower power generation level. Thus, the manual operation is costly on both human and financial levels. A device capable of clearing the clinkers is the proposed solution to the problem. The device should be automated where feasible and should keep personnel a safe distance from the hopper during fragmentation. With the problem sketched out, the steps of the design methodology in Section 1 are carried out.

In particular, we examine the subsystem that fragments the clinker. A functional model of the subsystem is shown in Fig. 16. Process choices (requirements by the customer) dictate that electric and pneumatic energy be used for the fragmenting operation. Note that the flow *probe* is considered an input to the subsystem and represents an expendable element of the device that is used to fragment the clinker. Since it is expendable (due to the dangerous conditions inside the hopper), it will have to be imported and exported from the device and it is appropriate to consider it a material flow. The module heuristics identify several possible modules, four of which are denoted as modules *A* through *D*. The branching flow *probe* suggests an unexpected result: the probe could be fitted with end effectors which fragment the clinker (the overlapping modules *B* and *C*) and which remove clinker fragments (module *D*). This means that the end effectors would have to be expendable as well. This presents an option that is not intuitively obvious, but is completely feasible. In fact, this option was implemented. The probe is embodied by an inexpensive steel pole (which also solves module *A*) and modified to allow end effectors (a small air hammer for the overlapping module *B* and *C*; a rake-like structure for module *D*) to screw onto it as shown in Fig. 17.

For two of the device's subsystems (one to move the device's fragmentation unit, the other to fragment the clinker), a unique module possible count of 14 is found. This application to a larger, more complex product supports the heuristics' utility for larger scale design problems.

4.2 A Sub-optimal Product

The power screwdriver example that accompanies the heuristics in Section 3 is a well optimized, modular product. Now we briefly examine a sub-optimal (in terms of modularity) product, an electric wok shown in Fig. 18, to see if the module heuristics can identify a promising modular product architecture.

Table 4 and Fig. 19 summarize the results of the product architecture design method for the electric wok. The customer needs³² are shown in Table 4 and indicate the current model lacks at least two customer requirements: 1) uniform heating in the bowl of the wok and 2) the ability to immerse it for cleaning. In Fig. 19, (a) shows the Black Box representation of the wok and (b) presents the functional model complete with the heuristically identified modules. Note that five potential modules are identified for the wok. Module A deals with electrical energy; B is associated with the conversion to and transmission of thermal energy; C follows the flow of food through the device; D deals with cleaning the device; and E identifies the structural requirements of the wok.

Next we check the electric wok of Fig. 18 for the existence of a modular architecture and any correspondence to the modules identified in Fig. 19 (b). It is evident from the disassembled view of Fig. 18 (b) that the wok is not a modular product. Many pieces exist, but few are collected together as modules. The heating ring (parts 8 - 10 from Fig. 18 (b)) most closely resembles module B, embodying the sub-functions *convert electricity to thermal energy* and *transmit thermal energy*. The two customer needs mentioned above can be addressed by adopting a modular architecture for the wok. In particular, the need to immerse the device for cleaning can be met by separating modules C and D from module A. Uniform heating can be achieved through a redesign of module B.

Two concepts for a redesigned wok are shown in Fig. 20. The first concept features a bowl (embodying modules C and D) which is separable from the rest of the device for cleaning purposes and a heating module which provides a more uniform temperature to the bowl. The second concept takes a different approach to meeting the customer needs. It assembles modules B, C, D and E together such that they can be immersed for cleaning. The electrical supply (module A) then plugs into the assembly to provide the necessary energy for use.

Thus, the module heuristics, a part of the product architecture design methodology, can take a non-modular product and identify a modular architecture that meets customer needs. Standard decision making techniques can be applied to determine which concept to develop. As a final note on this case study, the choice of a modular architecture allows this product to be easily updated in the future and presents the opportunity to share modules across products. For example, the heating ring or electrical supply module could be adapted from (or adapted to) a hot plate or skillet.

5 CONCLUSION

This paper introduces the three heuristic methods of dominant flow, branching flow and conversion-transmission function chains. These three methods provide a systematic approach to identifying modules of a product from a functional model. While their application is elegantly simple, they represent a novel and systematic approach to product architecture design. The methods were verified using a 70-product database of consumer products. What we can say with certainty is that the three heuristic methods identify all modules found in this consumer product class. Perhaps more importantly, the heuristics identify opportunities for increased product modularity and innovation.

The heuristic method presented here is part of a new tack on design methodologies. It shifts the focus to modular concept variants where solutions are sought at a modular level rather than a functional level. It also allows product architecture decisions to begin at a much earlier stage (i.e., the functional model stage).

6 EXTENSIONS TO THIS WORK

So far we have used function structures and three heuristic methods to identify sub-functions that can be grouped together as a modules. But how do we measure the value of modular design methodology versus integral or non-modular methodologies? From a cost point of view, methods exist to evaluate the economic viability of different architectures¹². However, customer need driven evaluation methods are less well developed. Since meeting customer needs is already a primary component of decomposition based design methodologies^{2,33}, work is underway on a quantitative method that develops a customer need ranking for a module. Additionally, forming development teams based on heuristically identified modules²⁴ is an area of active research.

ACKNOWLEDGMENTS

The research reported in this paper was partially supported by an Engineering Doctoral Fellowship through the College of Engineering and by a Continuing Fellowship, both awarded by The University of Texas at Austin. In addition, this work is supported, in part, by the National Science Foundation under both an NSF Young Investigator Award, Ford Motor Company, Desktop Manufacturing Corporation, Texas Instruments, W.M. Keck Foundation, and the June and Gene Gillis Endowed Faculty Fellow in Manufacturing. Any opinions or findings of this work are the responsibility of the authors, and does not necessarily reflect the views of the sponsors or collaborators.

REFERENCES

- ¹ **Ulrich, K and Tung, K** 'Fundamentals of Product Modularity' *Proceedings of the 1991 Winter Annual Meeting DE-Vol. 39* Atlanta, GA (1991) pp 73-79
- ² **Pahl, G and Beitz, W** *Engineering Design: A Systematic Approach* Springer-Verlag (1988)
- ³ **Congress** 'Green Products by Design: Choices for a Cleaner Environment' Office of Technology Assessment, OTA-E-541, Washington, D.C. (1992)
- ⁴ **Otto, K and Wood, K** 'A Reverse Engineering and Redesign Methodology for Product Evolution' *Proceedings of the 1996 ASME Design Theory and Methodology Conference 96-DETC/DTM-1523* Irvine, CA (1996)
- ⁵ **Bradley, S and Agogino, A** 'An Intelligent Real Time Design Methodology for Component Selection: An Approach to Managing Uncertainty' *Journal of Mechanical Design* Vol 116 (1994) pp 980-988
- ⁶ **Ward, A** *A Theory of Quantitative Inference Applied to a Mechanical Design Compiler* Doctoral Thesis, Massachusetts Institute of Technology (1989)

- ⁷ **Ward, A and Seering, W** 'Quantitative Inference in a Mechanical Design 'Compiler' ' *Journal of Mechanical Design* Vol 115 (1993) pp 29-35
- ⁸ **Schmidt, L and Cagan, J** 'Optimal Configuration Design: An Integrated Approach Using Grammars' To appear in *Journal of Mechanical Design* (accepted 1997)
- ⁹ **Schmidt, L and Cagan, J** 'GGREADA: A Graph Grammar-Based Machine Design Algorithm' To appear in *Research in Engineering Design* (accepted 1997)
- ¹⁰ **Vadde, S, Allen, J, and Mistree, F** 'Catalog Design: Design Using Available Assets' *Proceedings of the 1992 ASME Design Technical Conferences, Advances in Design Automation DE-Vol 44 No 1* Scottsdale, AZ (1992)
- ¹¹ **Gupta, S and Krishnan, K** 'Product Family-Based Integrated Component and Vendor Selection' Department of Management Working Paper, The University of Texas at Austin (1997)
- ¹² **Boothroyd, G and Dewhurst, P** *Product Design for Assembly* McGraw-Hill, Inc, New York (1989)
- ¹³ **Marks, M, Eubanks, C, and Ishii, K** 'Life-Cycle Clumping of Product Designs for Ownership and Retirement' *Proceedings of the ASME Design Theory and Methodology Conference DE-Vol. 53* (1993) pp 83-90
- ¹⁴ **Newcomb, P, Bras, B, and Rosen, D** 'Implications of Modularity on Product Design for the Life Cycle' *Proceedings of the 1996 ASME Design Theory and Methodology Conference 96-DETC/DTM-1516* Irvine, CA (1996)
- ¹⁵ **Pimmler, T and Eppinger, S** 'Integration Analysis of Product Decompositions' *Proceedings of the ASME Design Theory and Methodology Conference DE-Vol. 68* (1994) pp 343-351
- ¹⁶ **Rosen, D** 'Design of Modular Product Architectures in Discrete Design Spaces Subject to Life Cycle Issues' *Proceedings of the 1996 ASME Design Engineering Technical Conferences 96-DETC/DAC-1485* Irvine, CA (1996)
- ¹⁷ **Dixon, J R and Poli, C** *Engineering Design and Design for Manufacturing*, Field Stone Publishers, Conway, MA (1995)
- ¹⁸ **Cutherell, D** 'Chapter 16: Product Architecture' *The PDMA Handbook of New Product Development* M. Rosenau Jr. et al., ed., John Wiley and Sons, New York (1996)
- ¹⁹ **Krishnan, V, Singh, R, and Tirupati, D** 'A Model-Based Approach for Planning and Developing a Family of Technology-Based Products' Department of Management Working Paper, The University of Texas at Austin (1996)
- ²⁰ **Otto, K** 'Forming Product Design Specifications' *Proceedings of the 1996 ASME Design Engineering Technical Conferences 96-DETC/DTM-1517* Irvine, CA (1996)
- ²¹ **Hauser, J and Clausing, D** 'The House of Quality' *Harvard Business Review* May-June (1988) pp 63-73
- ²² **Otto, K and Wood, K** 'Conceptual and Configuration Design of Products and Assemblies' *ASM Handbook, Materials Selection and Design* Vol 20 ASM International (1997) pp 15-32
- ²³ **Little, A, Wood, K, and McAdams, D** 'Functional Analysis: A Fundamental Empirical Study for Reverse Engineering, Benchmarking and Redesign' *Proceedings of the 1997 Design Engineering Technical Conferences 97-DETC/DTM-3879* Sacramento, CA (1997)
- ²⁴ **Stone, R** *Towards a Theory of Modular Design* Doctoral Thesis, The University of Texas at Austin (1997)
- ²⁵ **Karnop, D, Margolis, D, and Rosenberg, R** *System Dynamics: A Unified Approach* John Wiley, New York (1990)
- ²⁶ **Miles, L** *Techniques of Value Analysis Engineering* McGraw-Hill, New York (1972)

- ²⁷ **Collins, J, Hagan, B, and Bratt, H** 'The Failure-Experience Matrix - a Useful Design Tool' *Transactions of the ASME, Series B, Journal of Engineering in Industry* Vol 98 (1976) pp 1074-1079
- ²⁸ **Stone, R, Wood, K, Crawford, R** 'A Heuristic Method to Identify Modules from a Functional Description of a Product' *Proceedings of DETC98* DETC98/DTM-5642 Atlanta, GA (1998)
- ²⁹ **Hundal, M** 'A Systematic Method for Developing Function Structures, Solutions and Concept Variants' *Mechanism and Machine Theory* Vol 25, No 3 (1990) pp 243-256
- ³⁰ **Murdock, J, Szykman, S, and Sriram, R** 'An Information Modeling Framework to Support Design Databases and Repositories' *Proceedings of DETC'97* DETC97/DFM-4373 Sacramento, CA (1997)
- ³¹ **McAdams, D, Stone, R, and Wood, K** 'Functional Interdependence and Product Similarity Based on Customer Needs' To appear in *Research in Engineering Design* (1998)
- ³² **Otto, K** 'Forming Product Design Specifications' *Proceedings of 1996 ASME Design Engineering Technical Conferences* 96-DETC/DTM-1517 Irvine, CA (1996)
- ³³ **Ullman, D** *The Mechanical Design Process 2nd ed.* McGraw-Hill, New York (1997)

Table 1 Function classes, basic functions and synonyms (Little *et al.*, 1997). Repeated synonyms are italicized. One function is selected as the verb in the verb-object description of a sub-function.

Class	Basic	Flow restricted	Synonyms	
Branch	Separate		Switch, Divide, Release, Detach, Disconnect, Disassemble, Subtract,	
		Remove	Cut, Polish, Sand, Drill, Lathe	
	Refine		Purify, Strain, Filter, Percolate, Clear	
	Distribute		Diverge, Scatter, Disperse, <i>Diffuse</i> , Empty	
Channel	Dissipate		Absorb, Dampen, Dispel, <i>Diffuse</i> , Resist	
	Import		Input, Receive, <i>Allow</i> , Form Entrance, <i>Capture</i>	
		Export		Discharge, Eject, Dispose, Remove
	Transfer			
		Transport		Lift, Move, Channel
		Transmit		Conduct, Transfer, Convey
	Guide			Direct, Straighten, Steer
		Translate		
		Rotate		Turn, Spin
Allow DOF			Constrain, Unlock	
Connect	Couple		Join, Assemble, <i>Attach</i>	
	Mix		Combine, Blend, Add, Pack, Coalesce	
Control Magnitude	Actuate		Start, Initiate	
	Regulate		Control, <i>Allow</i> , <i>Prevent</i> , Enable/Disable, Limit, Interrupt, Valve	
	Change		Increase, Decrease, Amplify, Reduce, Magnify, Normalize, Multiply, Scale, Rectify, Adjust	
	Form		Compact, Crush, Shape, Compress, Pierce	
Convert	Convert		Transform, Liquefy, Solidify, Evaporate, Condense, Integrate, Differentiate, Process	
Provision	Store		Contain, Collect, Reserve, <i>Capture</i>	
	Supply		Fill, Provide, Replenish, Expose	
	Extract			
Signal	Sense		Perceive, Recognize, Discern, Check, Locate	
	Indicate		Mark	
	Display			
	Measure		Calculate	
Support	Stop		Insulate, Protect, <i>Prevent</i> , Shield, Inhibit	
	Stabilize		Steady	
	Secure		<i>Attach</i> , Mount, Lock, Fasten, Hold	
	Position		Orient, Align, Locate	

Table 2 Flow classes, basic and sub-basic flows and complements (Stone, 1997). A flow selected from the list fills the object spot of the verb-object description.

Class	Basic	Sub-basic	Complements	
Material	Human		Hand, foot, head ,etc.	
	Gas			
	Liquid			
	Solid			
Signal	Status	Auditory	Tone, Verbal	
		Olfactory		
		Tactile	Temperature, Pressure, Roughness	
		Taste		
		Visual	Position, Displacement	
	Control			
Class	Basic	Sub-basic	Bond graph based complement	
			Effort analogy	Flow analogy
Energy	Human		Force	Motion
	Acoustic		Pressure	Particle velocity
	Biological		Pressure	Volumetric flow
	Chemical		Affinity	Reaction rate
	Electrical		Electromotive force	Current
	Electromagnetic	Optical	Intensity	Velocity
		Solar	Intensity	Velocity
	Hydraulic		Pressure	Volumetric flow
	Magnetic		Magnetomotive force	Magnetic flux rate
	Mechanical	Rotational	Torque	Angular velocity
		Translational	Force	Linear velocity
		Vibrational	Amplitude	Frequency
	Pneumatic		Pressure	Mass flow
	Radioactive		Intensity	Decay rate
Thermal		Temperature	Heat flow	
Usage & Degree of Specification				
Class only Least Specific*				
	<i>Basic or Sub-basic + Class</i> More Specific*			
	<i>Basic or Sub-basic + Complement</i>			Most Specific*
Overall increasing degree of specification *				

Table 3 Statistical comparison of identified modules and actual modules in 18 products.

Product	Identified modules			Actual modules			Unique module poss.	Actual module total
	Dom. flow	Branch. flow	Conv.-Trans.	Dom. flow	Branch. flow	Conv.-Trans.		
Mr. Coffee iced tea/ coffee brewer	6	4	1	5	3	1	7	6
West Bend iced tea/ coffee brewer	6	4	1	4	3	1	7	5
Mr. Coffee coffee maker	5	3	1	3	1	1	6	3
B&D screwdriver	4	5	1	2	3	0	6	4
SKIL screwdriver	4	5	1	3	3	0	6	5
DeWalt sander	4	4	3	4	3	3	9	7
Bissel hand vacuum	5	3	2	4	2	2	6	6
Pencil sharpener	3	2	1	3	2	1	4	4
B&D electric knife	3	4	2	2	2	2	6	4
Presto air popcorn popper	3	2	3	3	2	3	8	6
Krups cafe trio	3	2	1	3	1	1	6	5
B&D sander	5	2	3	3	2	3	7	6
Dazey fruit/veggie peeler	5	3	2	3	2	2	7	4
Dremel engraver	3	4	1	2	2	1	5	3
1974 Chevy tailgate	3	6	1	2	3	1	5	3
B&D VersaPak trimmer	4	2	1	4	2	1	5	5
Cadillac visor	2	0	2	2	0	2	4	2
Super Maxx ball shooter	3	2	2	3	0	2	6	3
Average	4	3	2	3	2	2	6	4

Table 4 Partial customer needs list for an electric wok³². Needs are ranked on a [1=nice, 5=must] scale.

Group	Customer need	Ranking
Clean	Non-stick surface	4
	Watertight	2
	Detachable from heating unit	2
On/off	Heats and cools quickly	3
	Long extension cord	3
	Temperature switch readable	1
	Off switch included	1
Add food	Large volume capacity	2
	Temperature indicator	1
	Temperature controls remain cool/ don't get hot	1
Cook food	Flat bottom for frying	1
	Small, rounded bottom for stir fry	5
	No ridges on inner surface	2
	Able to stand on its own	3
	Detachable heating unit to remove heat when cooking	1
	Temperature uniform across inner surface	5
	Steady-state temperature uniform	2
	Capable of high temperature	1
	Handles remain cool/ don't get hot	2

Figure captions:

- Figure 1 Examples of integral products: wrenches (top) and screwdrivers(top). All functions are embodied by one physical element.
- Figure 2 Examples of modular products. Black and Decker's VersaPak line uses the same battery units for a wide range of products.
- Figure 3 An overview of the Product Architecture Design Methodology.
- Figure 4 A Black Box model for a power screwdriver.
- Figure 5 Examples of two function chains for a power screwdriver. (a) A sequential function chain for the flow of *electricity* and *torque*. (b) A parallel function chain for the flow of *human force*.
- Figure 6 The functional model for a power screwdriver.
- Figure 7 Dominant flow heuristic applied to a generic function structure.
- Figure 8 Modules identified by the dominant flow heuristic from a function structure of the SKIL Twist power screwdriver.
- Figure 9 Views of the SKIL Twist power screwdriver.
- Figure 10 Schematic of a possible *supply electricity module* for the SKIL power screwdriver. The side view is shown in (a) and the end view in (b).
- Figure 11 Flow branching heuristic applied to a generic function structure.
- Figure 12 Modules identified by the flow branching heuristic from a function structure of the SKIL Twist power screwdriver.
- Figure 13 Conversion-transmission applied to a generic set of sub-functions.
- Figure 14 Module identified by the conversion-transmission heuristic from a function structure of the SKIL Twist power screwdriver.

- Figure 15 Cross sectional schematic of a power generation plant's boiler bottom. To Appear in *Design Studies*.
- Figure 16 A functional model of the fragment clinker subsystem.
- Figure 17 The modular probe and end effector schematic for the clinker clearer (a) and the actual air hammer that serves as the end effector module.
- Figure 18 The electric wok (a) assembled and (b) disassembled.
- Figure 19 (a) A Black Box representation of the electric wok. (b) A functional model of the electric wok with heuristically identified modules.
- Figure 20 Two concept variants for an electric wok with a modular architecture.

To Appear in *Design Studies*.

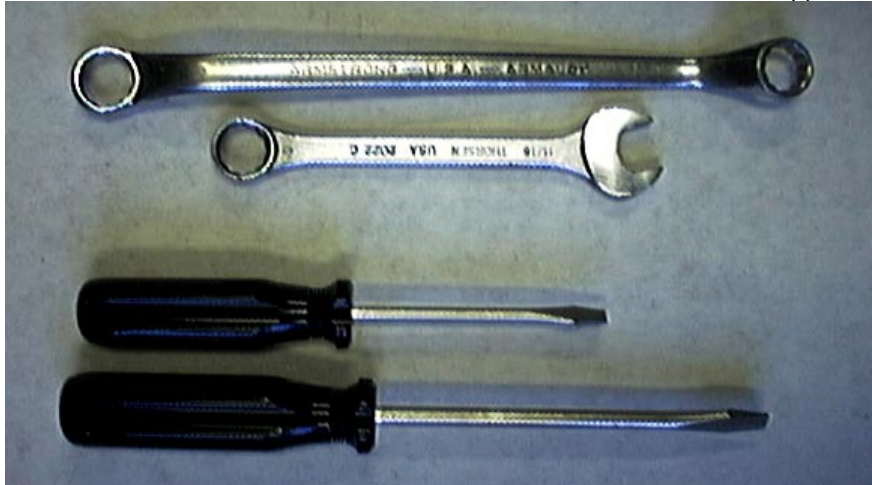

To Appear in *Design Studies*.

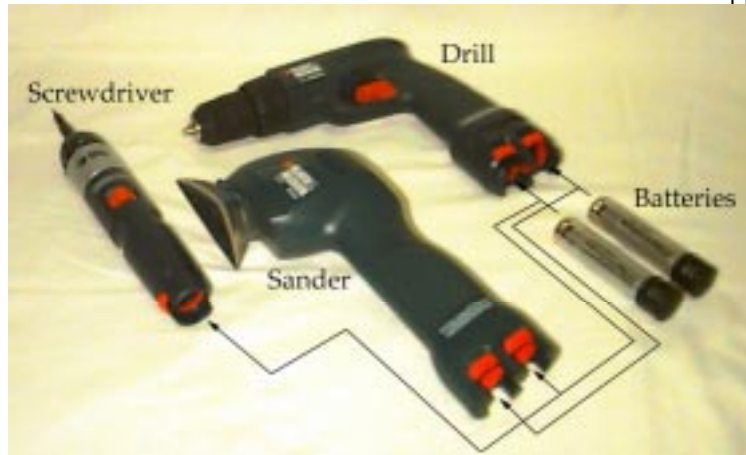

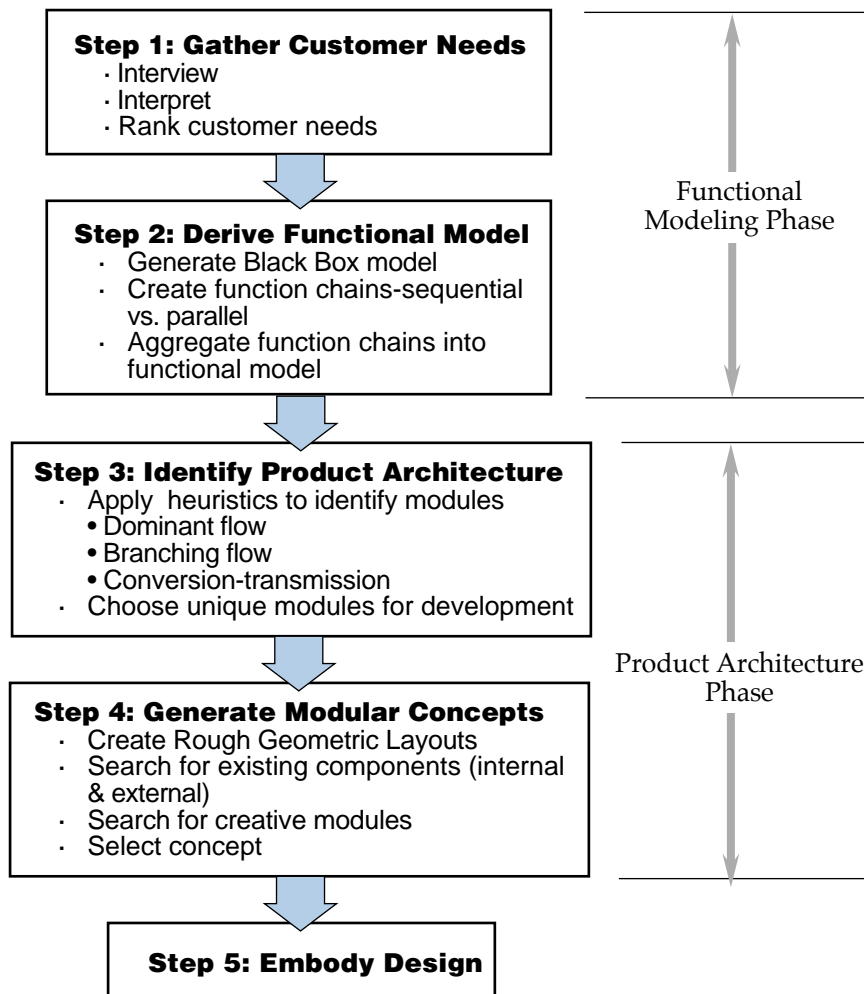

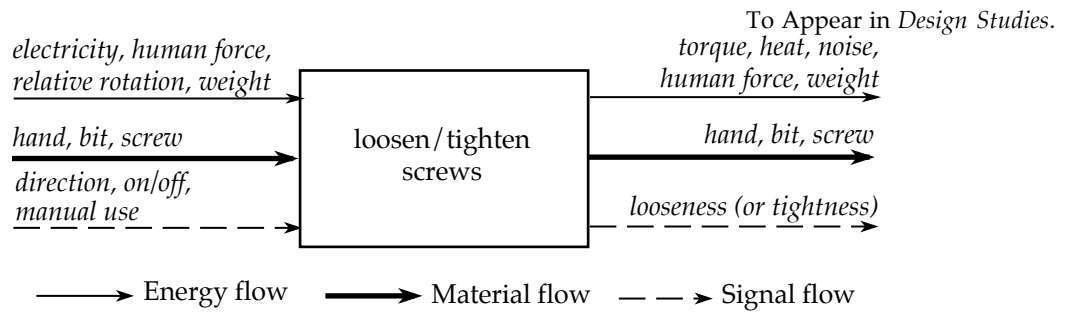

To Appear in *Design Studies*.

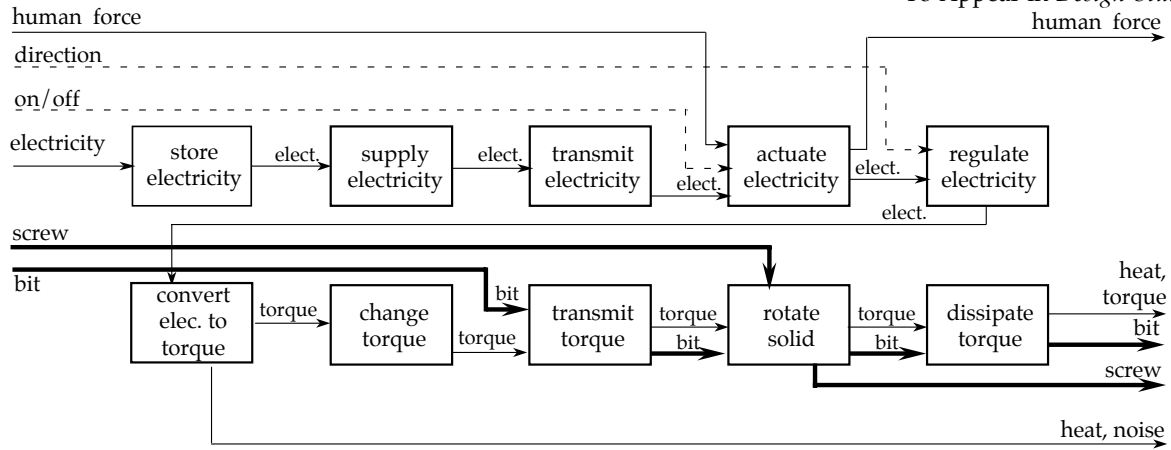

(a)

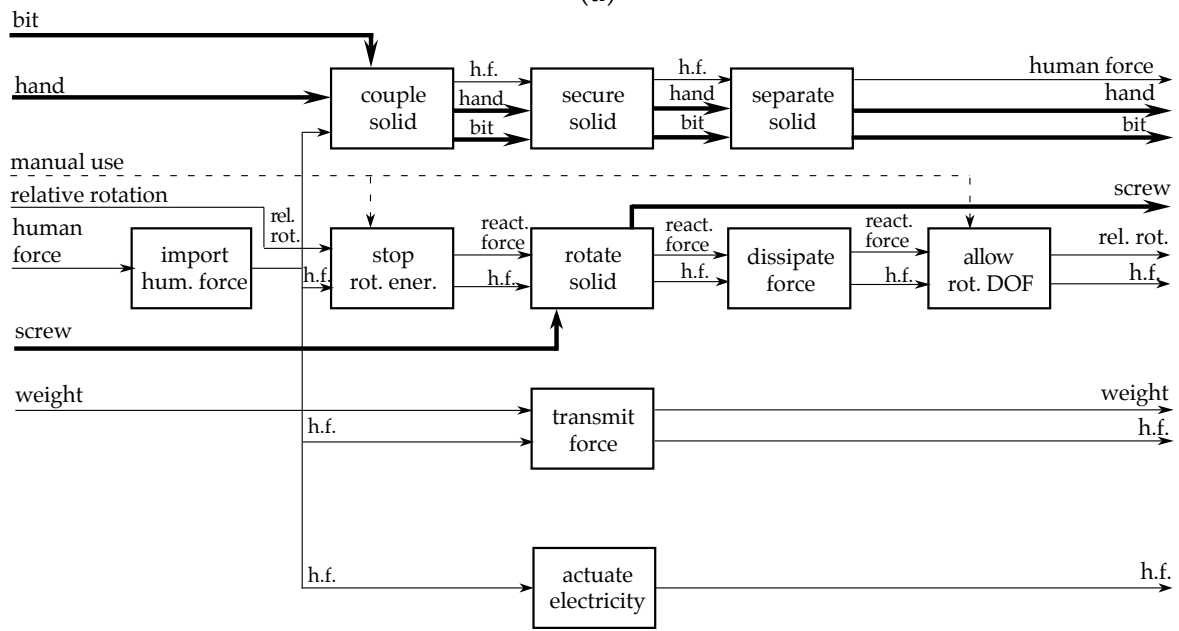

(b)

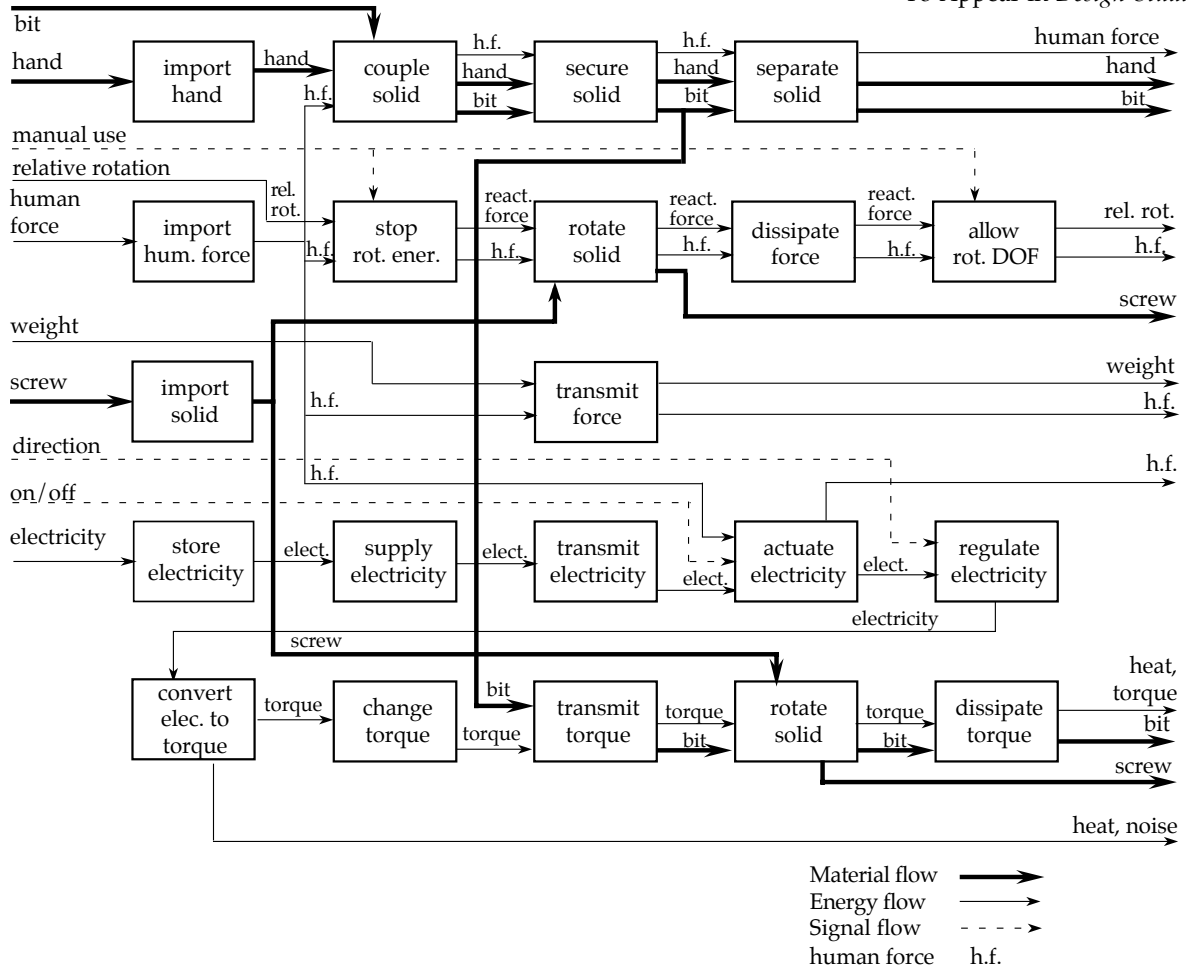

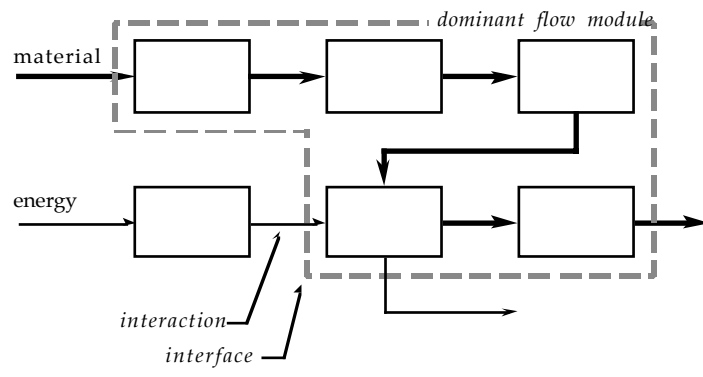

To Appear in *Design Studies*.

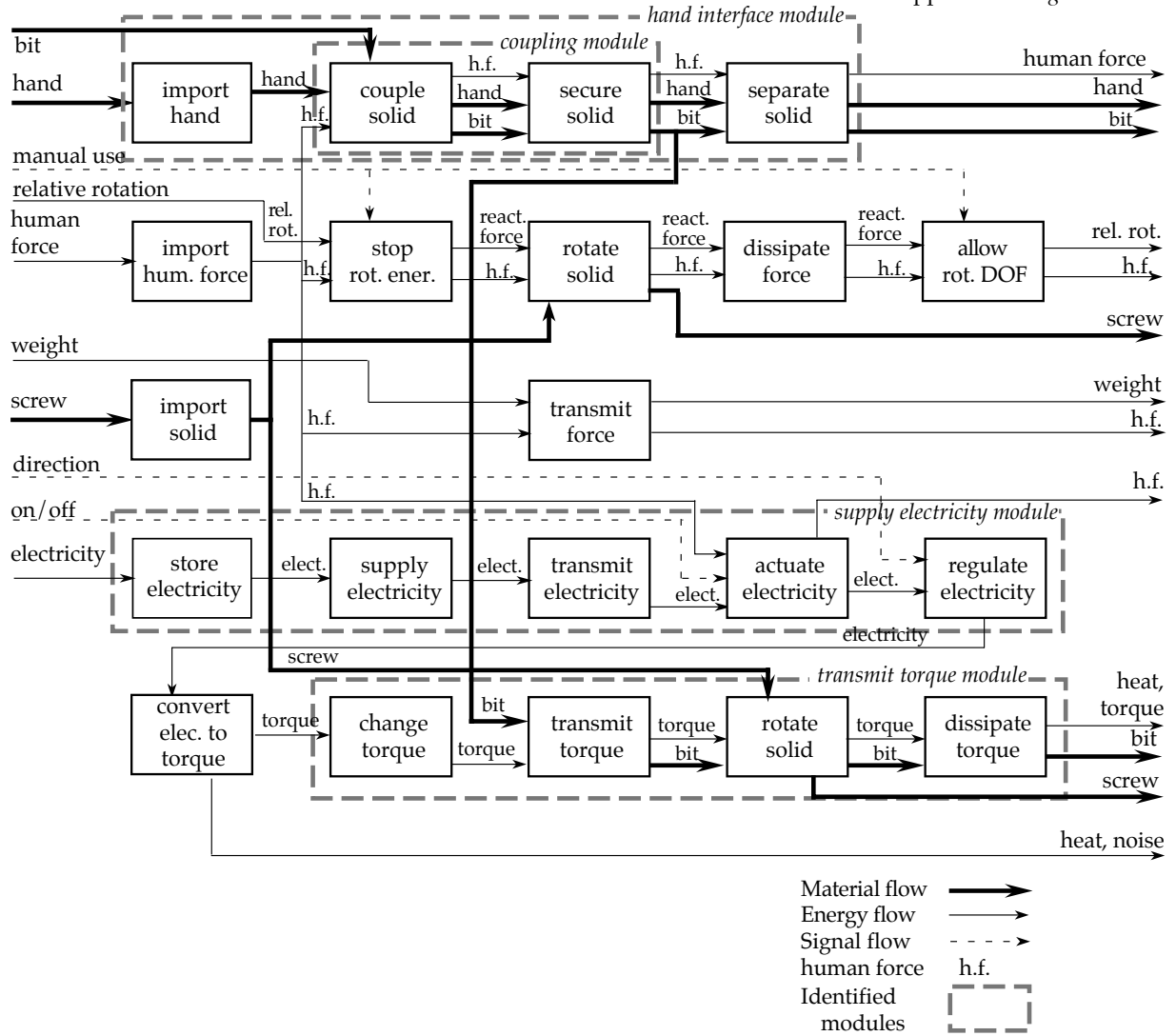



(a) Overview



(b) Exploded view

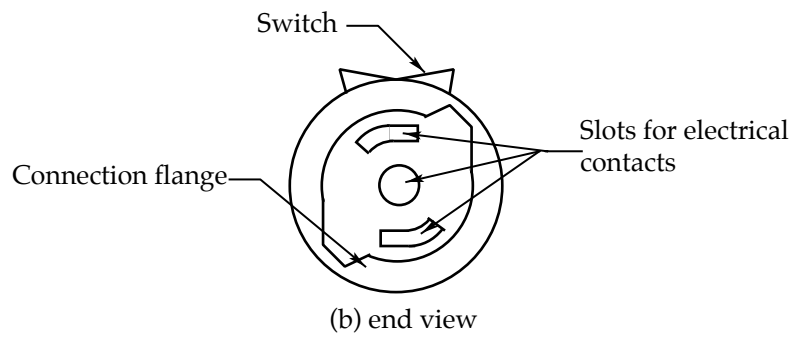
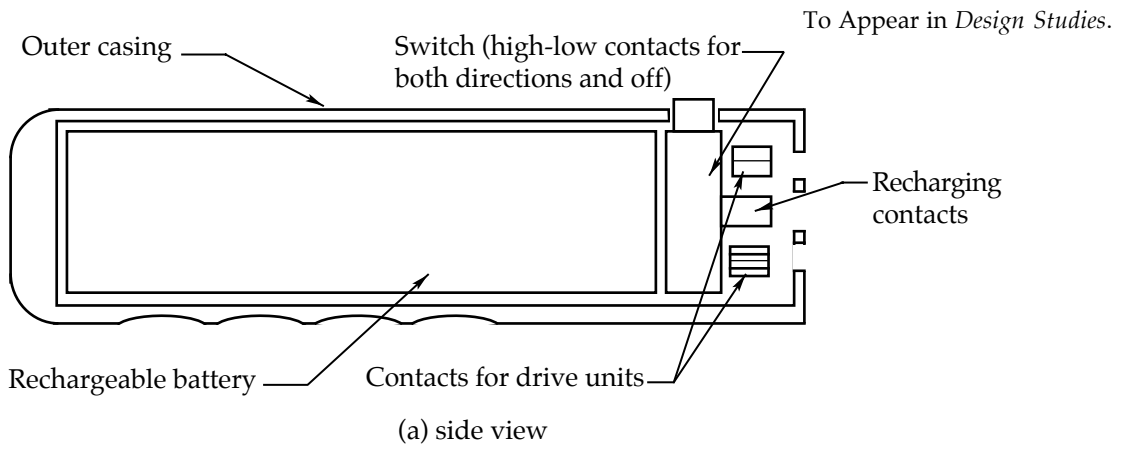

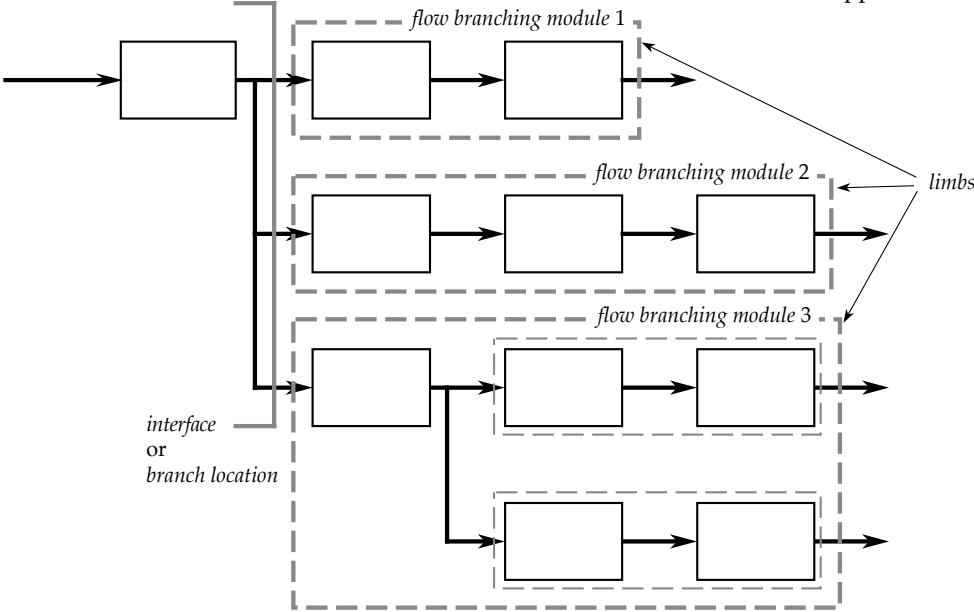

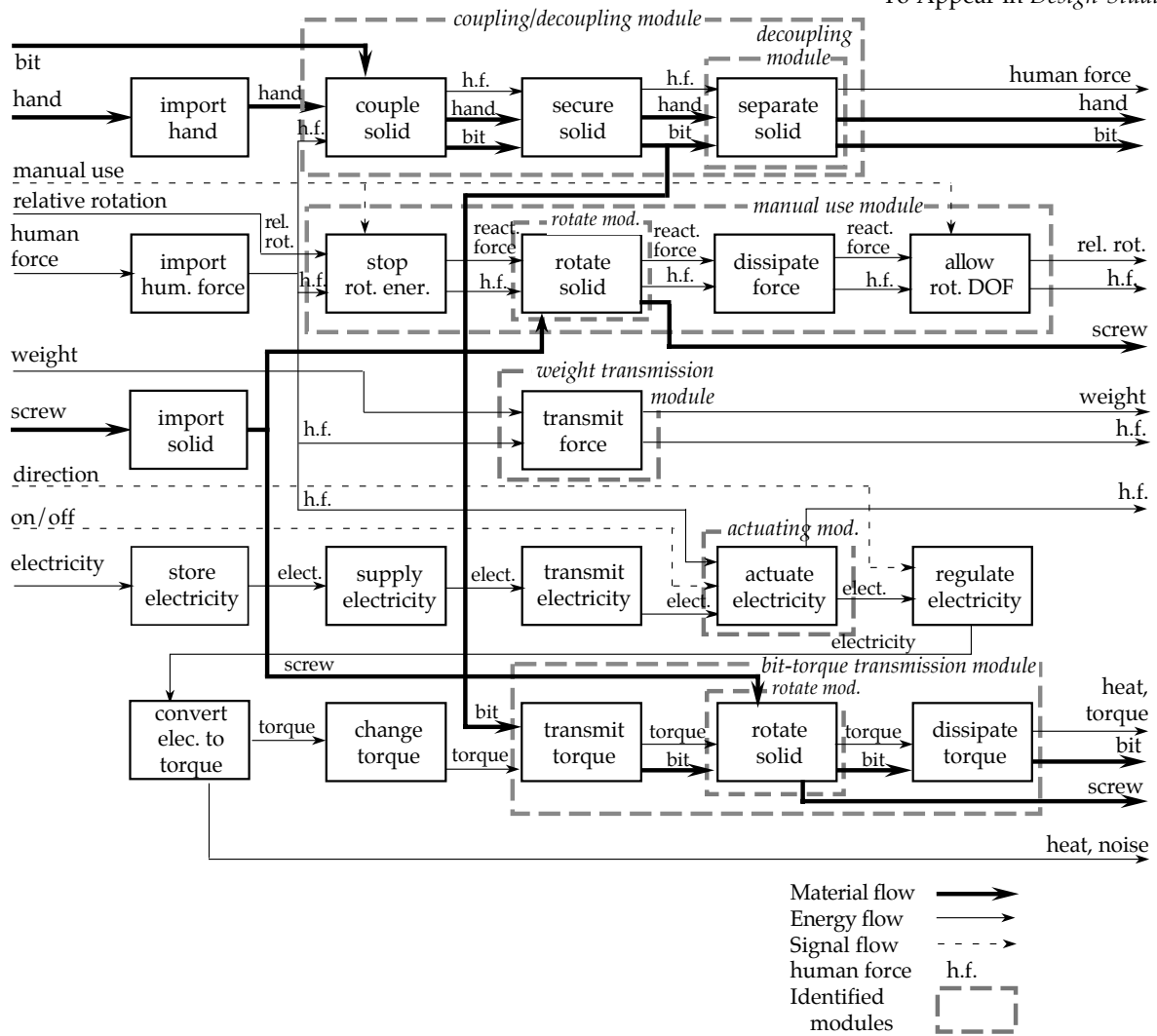

To Appear in *Design Studies*.

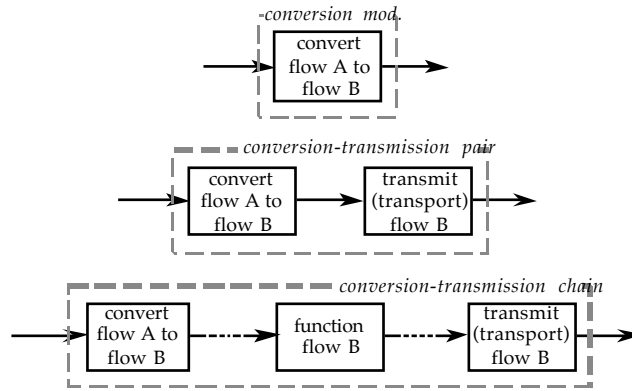

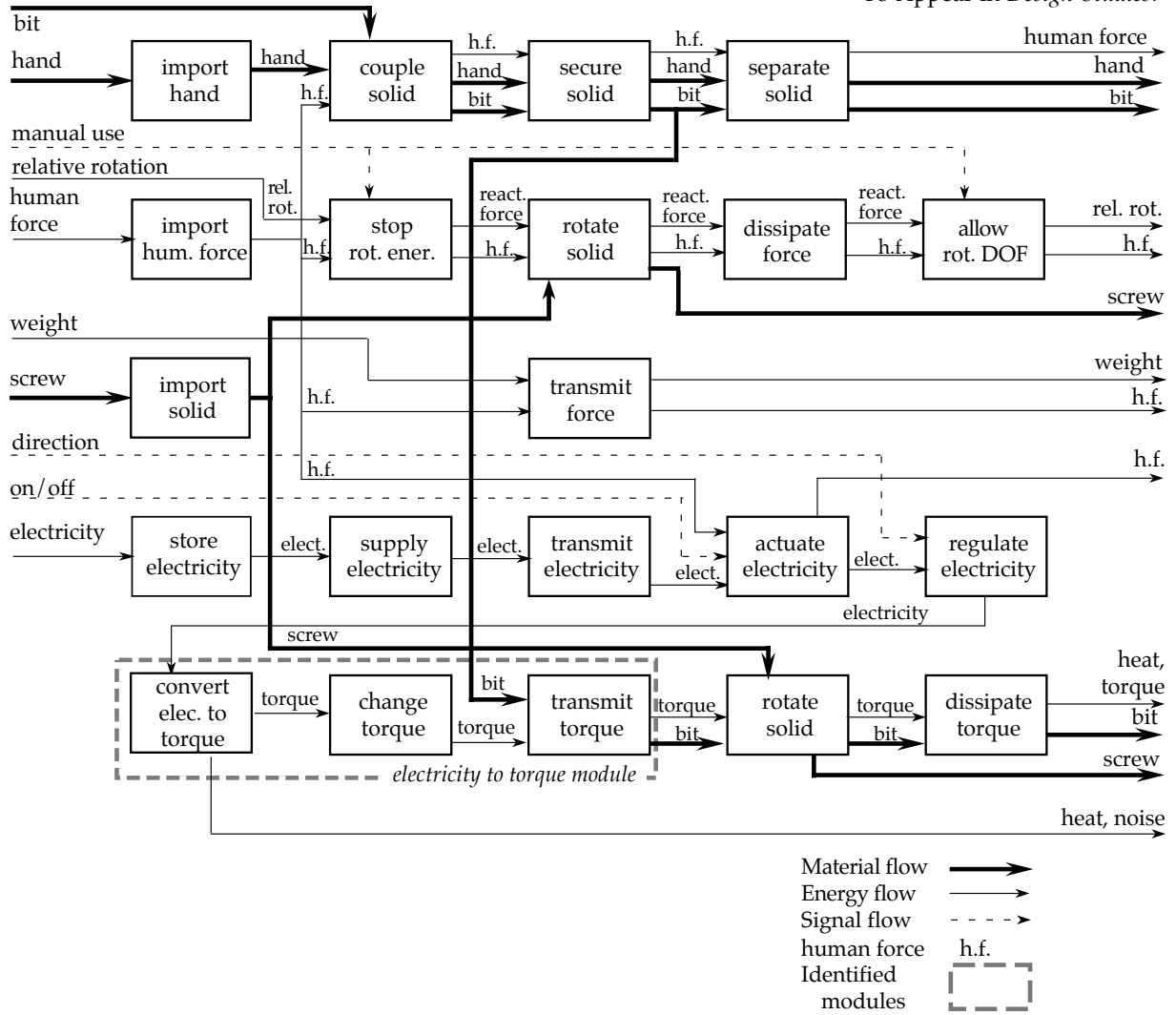

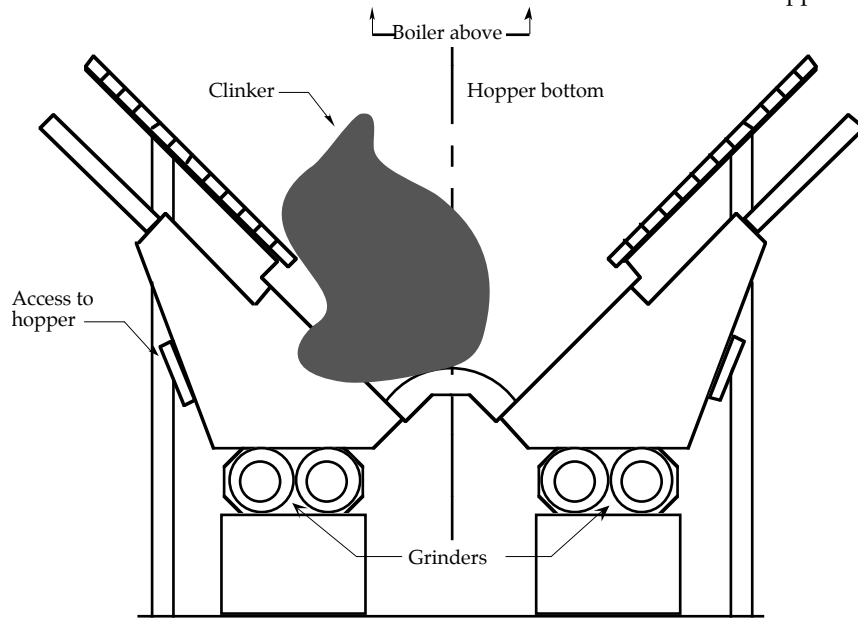

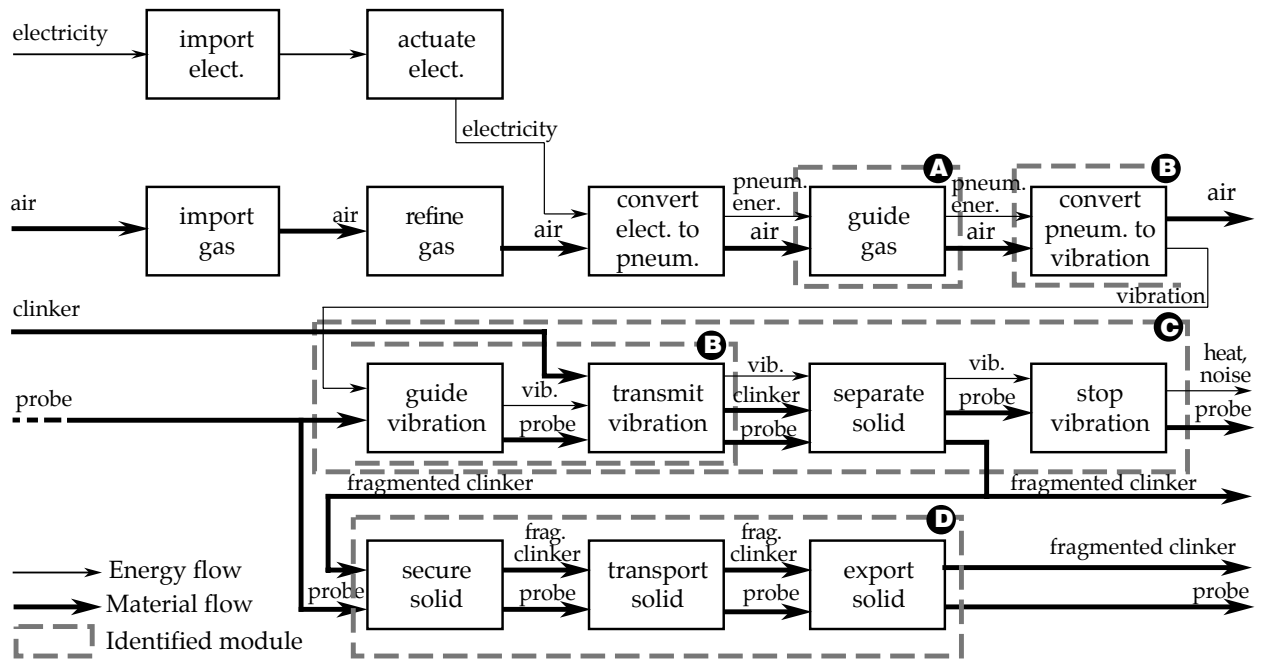

To Appear in *Design Studies*.

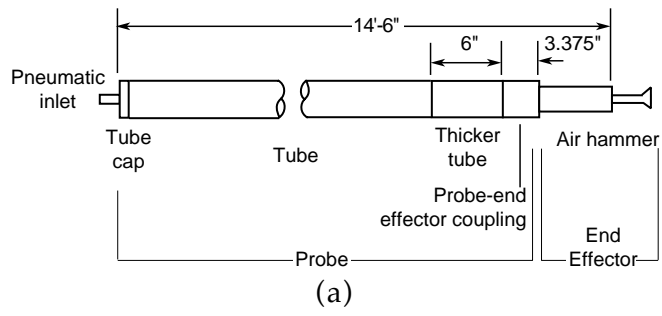

(b)



(a)



(b)

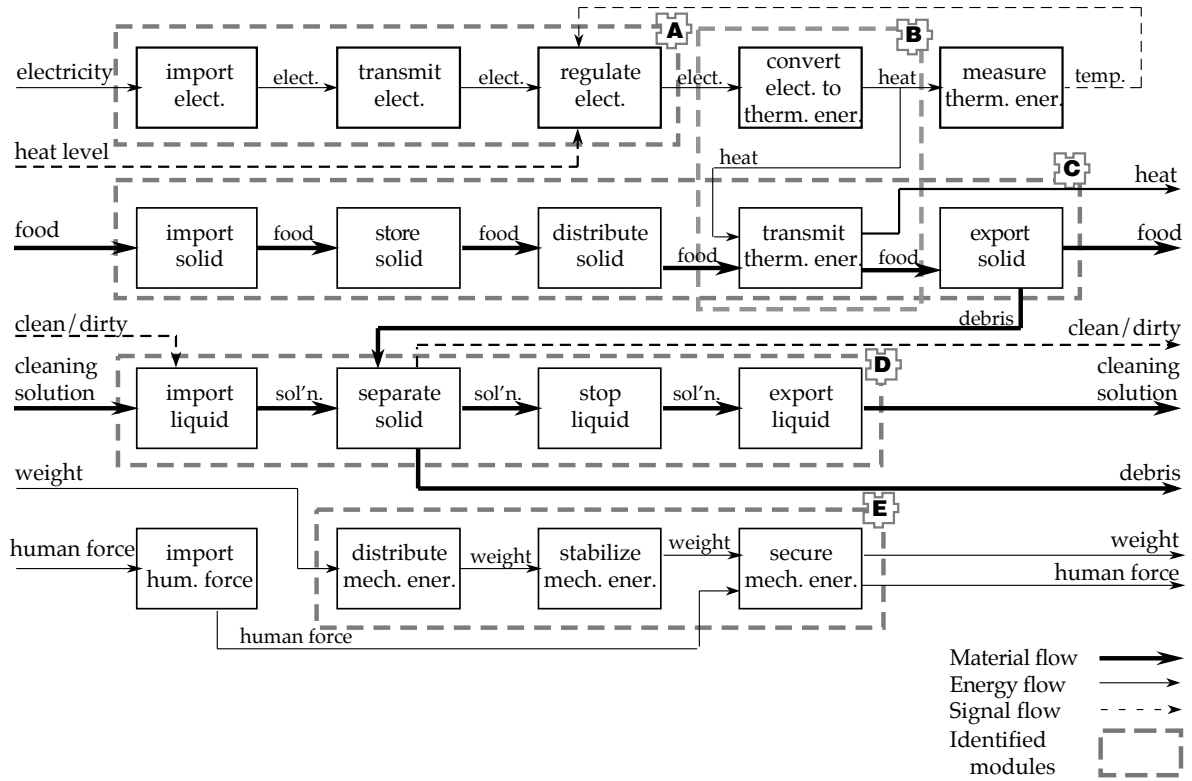
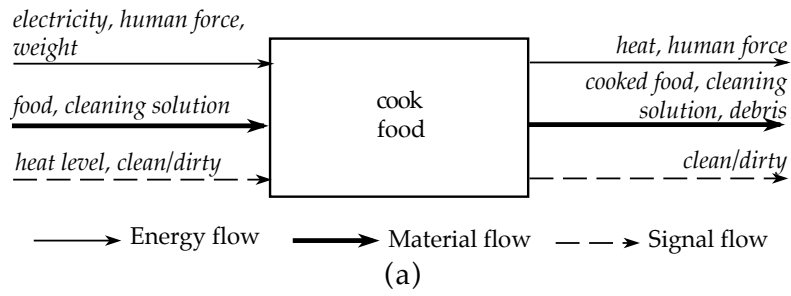

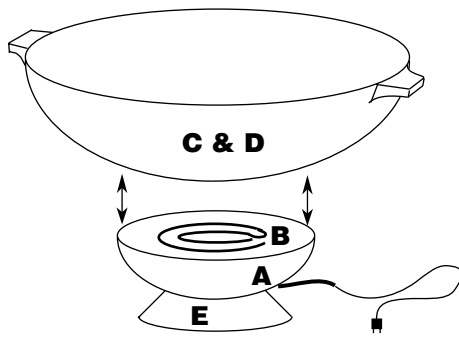

(a)

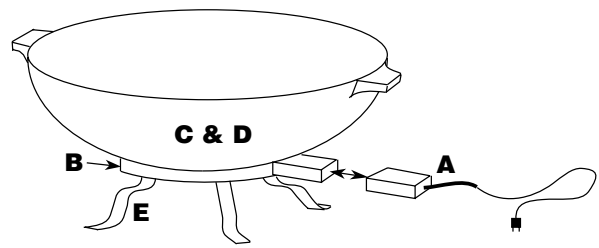

(b)